

# Leica Geosystems

Intelligent solutions for  
heavy construction



[leica-geosystems.com](http://leica-geosystems.com)



- when it has to be **right**

**Leica**  
Geosystems

# TABLE OF CONTENTS

## Intelligent jobsite

Leica ConX	4
HxGN SmartNet	6
iCON office	7
Safety Awareness Solutions	8

## Off-machine

iCON site	20
Tablets	22
GNSS antennas	24
Total stations	28
Leica AP20 AutoPole	30

## On-machine

Panels	34
Machine Smart Antenna	38
GNSS receivers	39
Excavate	40
Grade	54
Loaders	68
Rig	76
Compaction	88
Paving & Milling	92

## Services

Customer Care Package	112
-----------------------	-----



# Leica ConX

Gain the ultimate transparency into your construction activity and monitor progress in real time from anywhere on any device.



## Leica ConX

**Visualise and share data through a powerful cloud solution and web interface**

This cloud-based collaboration tool allows you to efficiently manage all your connected construction projects and to share job-related data with all stakeholders. Leica ConX enables you to visualise and validate localised reference models, survey data and constructed data with powerful analysis tools for monitoring and reporting site productivity.

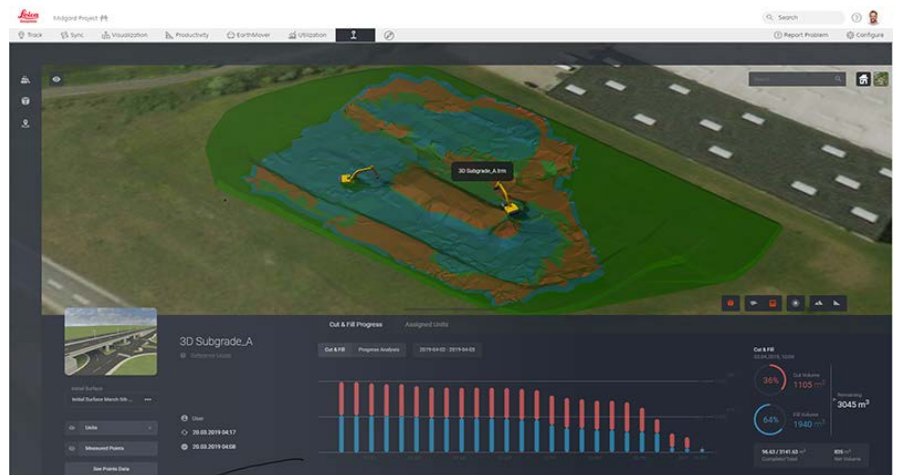



- Monitor the cut and fill situation in real-time
- Visualise designs localised on a 3D project map for quick and easy data validation
- Assign and automatically share designs and updates to 3D machines and surveyors
- Connect Leica desktop applications to ConX projects for direct field and office data sharing
- Minimise downtime with immediate remote support and trouble shooting

- Aggregate measured points from all connected sensors in real time
- Simple tools for analysing measured point data by source, time and design
- Powerful real time cut and fill analysis tool for monitoring project progress
- Current and historical volume calculating for automated project productivity analysis and reporting

# HxGN SmartNet Services

## We have you covered. Everywhere.

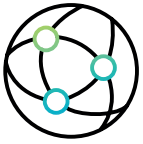

### Widest Network Coverage

With an extensive and continuously growing network, experience HxGN SmartNet's incredible accuracy and reliable coverage in more places across the world than any other service.



### Reliable Service

We ensure maximum service uptimes by investing in the most current technology and continually upgrading and maintaining our network's hardware infrastructure.



### Speaking your Language

Catering to a wide range of users and licensing needs with varying local requirements, our local and global service teams can assist you in your language.

## HxGN SmartNet Service Options



HxGN  
SmartNet NRTK

Provides coverage in regions across the world through our extensive reference station network.



HxGN  
SmartNet | PPP

Enables seamless positioning via satellite, offering centimetre-level accuracy anywhere in the world.

# iCON office – Relates the construction site with your **design data**

Whether processing survey data from a wealth of sensors or creating a 3D terrain map from your UAV or Lidar point cloud, iCON office is your tool to understand and visualise the terrain situation on-site at any moment of the construction process. A wide range of design file formats can easily be imported, validated, and converted to reference models used by various machine types and tasks. You can calculate the quantity differences between field, machine tasks and design targets within a few mouse clicks. With iCON office, you gain valuable insights into the project's progress and the quality of the work done.

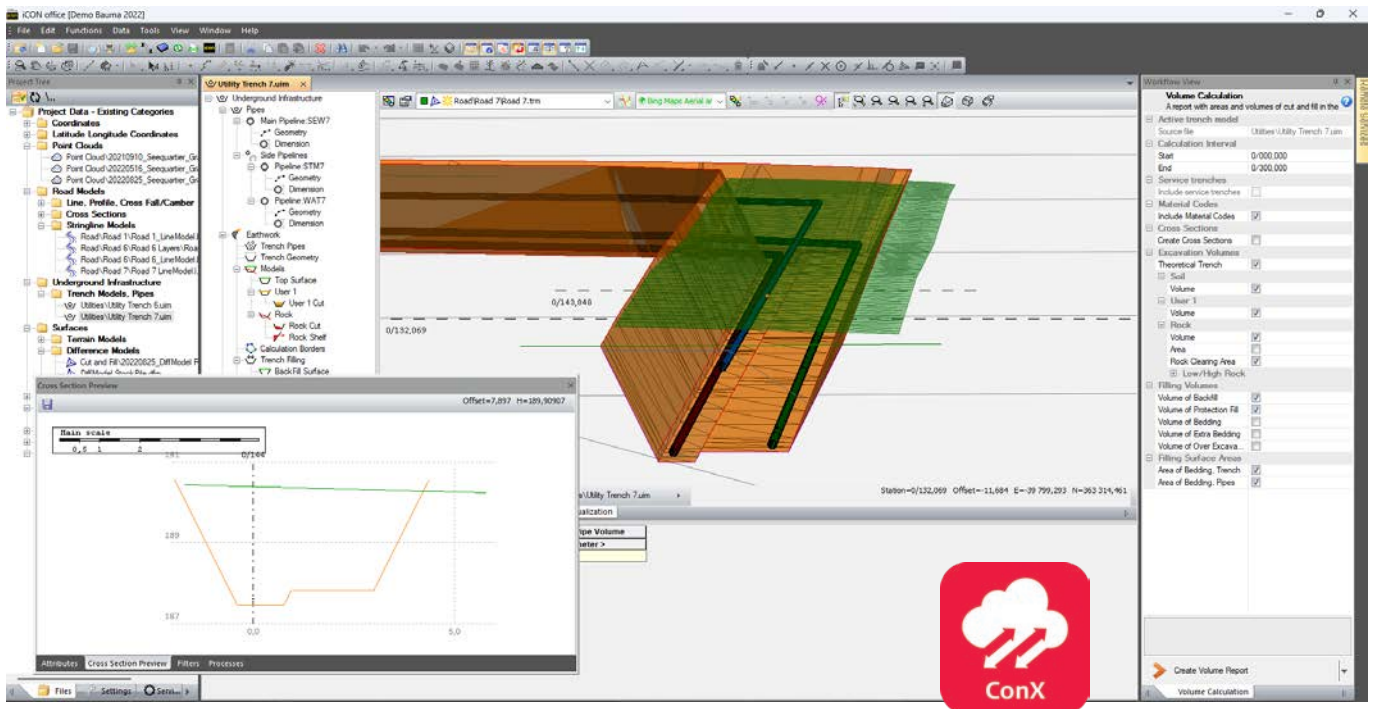

## Direct connection to field units via Leica ConX

iCON office provides a seamless data flow from office to field via the web-based ConX data service. The iCON office project map shows the location of all connected machines in real time. Share design files with machines and retrieve as-built data directly from your equipment with the integrated connectivity between iCON office and Leica ConX.

## Work with a range of different design models

Different design entities from simple road alignments to more complex road stringline, cross-section or layer models as well as digital terrain models and background maps may be used with Leica iCON office.

## Share your reference data to all machines and sensors, even in a mixed fleet project

Leica iCON office is compatible with many different machine control brands. The software supports a range of machine control systems and measurement sensors from Leica Geosystems as well as other manufacturers.

## Calculate cost estimates using as-built volume analysis

Amongst a suite of 8 modules, you can opt for installing the Terrain module. It allows accurate surface-to-surface volume calculation for cost estimation and planning purposes. This module offers complete control of the 3D design models used for mass calculation, including boundaries and break lines. The module may also be used for creating terrain profiles and sections and machine reference surface models.

## Easy and quick quality control reporting

Leica iCON office offers various standard reports for quality control reporting. Statistical checks and tolerance reports of deviations with respect to a design surface can be created at the click of a button.

## Save time and costs

The iCON office package has an easy-to-use interface assuring a short learning curve while appreciating its value. Use the self-training package delivered with the software or take advantage of one year's free technical support that is included with the licence. In addition to the simple user interface, Leica iCON office works the way you are used to, using the built-in AutoCAD® engine to open and edit native AutoCAD® drawings.

# Safety Awareness Solutions – Real-time safety awareness solutions for the entire site

Leica Geosystems offers a Modular Safety Awareness Solution to increase worker safety awareness and visibility between workers and machine operators to prevent machine-to-people, machine-to-machine, and machine-to-objects collisions. The possibility of integrating personal alert solution and collision avoidance technology with Leica Geosystems Machine Control solution offers a unique solution that can raise worker awareness and help prevent accidents on site.



## Personal Alert, PA10

Leica PA10 combines a tag worn by personnel moving around on foot that can communicate with a stand-alone panel inside machines or vehicles on sites.



## Collision Avoidance, CAS

CAS can be added to both PA10 and PA80 solutions. Integrating personal alert and collision avoidance technology with Leica Geosystems machine control offers a unique solution to elevate workers' awareness and decrease incidents on site.



## Personal Alert integrated with machine control, PA80

Leica PA80 combines the tag worn by personnel moving around on foot and the MC1 machine control solution.



## 3D Avoidance Zone system

Leica Geosystems and Xwatch Safety Solutions have jointly developed a new solution to safeguard construction assets and infrastructure on site.



## Visual Aid, VA80

Extends the operator's visibility and can capture images by integrating the CRS140 IP Camera and Leica MC1.



## ConX Safety Awareness Module

The Leica ConX Safety Awareness module collects data and alerts generated from iCON PA10, PA80, CAS and 3D Avoidance Zone systems and takes safety tracking and reporting to the next level.





# Safety Awareness Solutions – Increased awareness for all on the construction site

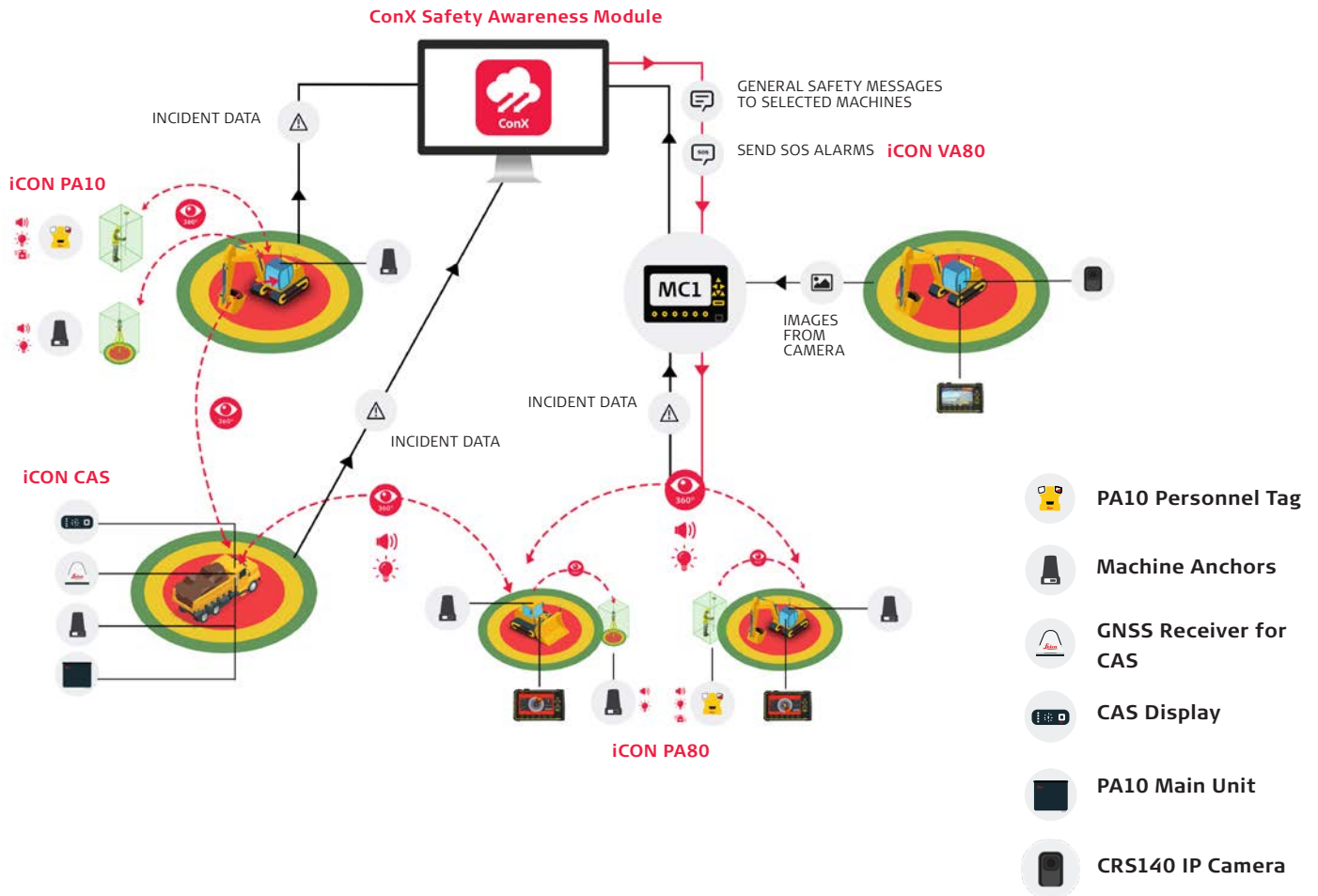

# Leica iCON PA10 – Prevent machine-to-people collisions



Leica PA10 combines a tag worn by personnel moving around on foot that communicates with all machines and vehicles on a heavy construction site. The solution provides three configurable alert distances around the machine or vehicle. It provides audio, visual, and vibratory feedback to the pedestrian and visual and audible feedback to the machine operator or driver to create awareness and a safer working environment.



# Leica iCON PA80 – Personal alert **integrated** with MC1 machine control software



The Leica PA80 allows for integration with the MC1 machine control solution for all applications. The machine operator receives visual and audible warnings on the in-cabin display.

Pedestrians can trigger a tag panic alert that will notify machine operators with Leica PA10 or PA80 within 50 m of an incident, ensuring immediate awareness of the situation. The panic alerts also notify operations with a CAS system within a 250 m range, further enhancing safety measures.

Low battery warnings will occur with on-site tags that have less than 20% battery life. The warning will be sent to all MC1 machines within the 50 m range and displayed on the run screen in the cabin, together with the tag serial number and tag location.

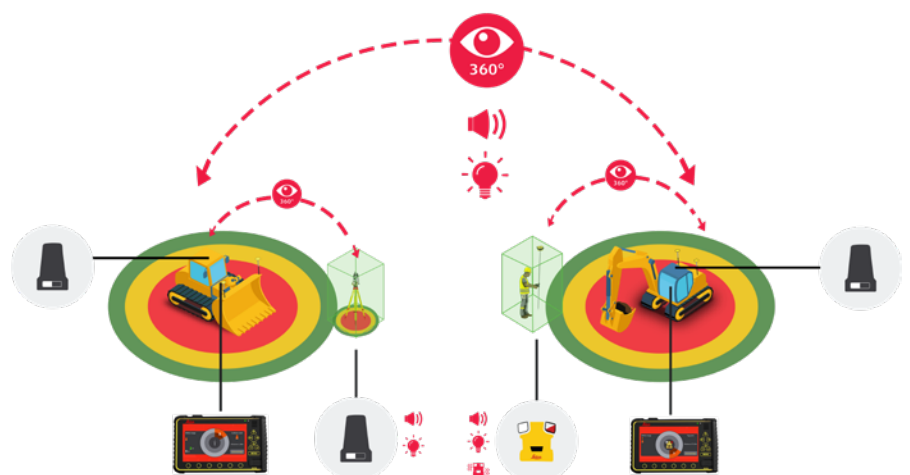

# Leica iCON VA80 – Extend operator's visibility with a camera

Extend the operator's visibility and capture images by integrating the CRS140 IP Camera and Leica MC1 to your fleet. With a 120 degrees field of view, this plug-and-play IP camera can capture real-time situation photos with associated geographic location when utilizing MC1's single logged functionality. The images can be synched to both USB and Leica ConX for export. Additionally, office personnel can access the camera stream in real-time via ConX remote view and view situations from the construction site.



# Collision Avoidance Solution – Avoid machine accidents with CAS

Collision Avoidance can be added to both the Leica PA10 and PA80 solutions to prevent machine to machine collisions on your construction site. With CAS you can define a speed, and if a driver exceeds the defined speed, an alarm will signal. Predefined areas or obstacles can be assigned to have specific alarms. With a CAS system, we can “talk” to other machines over 800 m away and calculate potential collisions from much further distance than the PA anchors.

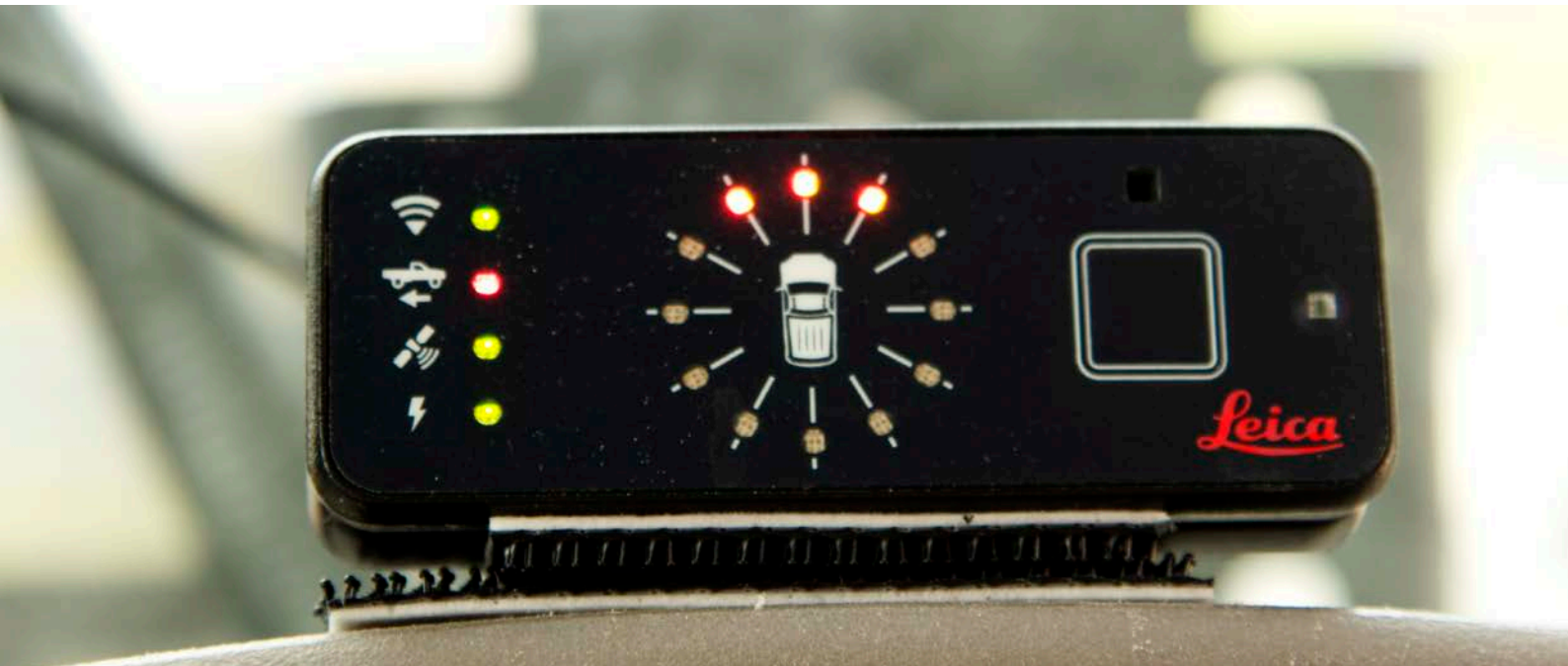

# ConX Safety Awareness Module – A **proactive** approach to safety

Heavy construction is one of the most dangerous industries, making on-site safety an important topic. The Leica ConX Safety Awareness module takes construction site safety to the next level by collecting data and alerts generated from iCON PA10, PA80 and CAS solutions and introducing its safety awareness system to communicate with a cloud platform. Easy visualisation, filtering and export of safety awareness data introduces a more proactive approach to safety.



#### NOTIFY FIELD CREW IN CASE OF EMERGENCY

- Send S.O.S. alerts from the office to the field and inform your crew promptly in case of emergency
- Alert field crew of events, let it be anticipated or unforeseen (such as blasting or storms)
- Send general or S.O.S. safety alerts to all members at once
- Send safety messages to specific users and machines, selected from a list



## The benefits of data-based insights

Utilising collected safety data is a demanding, yet essential element of efficient field safety management. The Leica ConX Safety Awareness module supports this task by integrating field-generated safety data into its cloud-based collaboration platform. The data driven insight provided by the module supports safety related decision-making through a user-friendly interface. This enables users not only to collect and review data but also to assess the entire operation over space and time, thereby it increases field crew safety and prevents accident-related delays.



### KEY FEATURES

- Filter data by event, equipment type, specific machine or event danger level
- Visualise selected data on a map
- Export customised data for further analysis
- Awareness API for interfacing to third-party systems
- Track incident data easily with dashboards and measure the impact of new safety measures

# 3D Avoidance Zone System

Leica Geosystems and Xwatch Safety Solutions have jointly developed a new solution to safeguard construction assets and infrastructure on site. This solution is possible by combining the state-of-the-art Leica MC1 machine control software and the top-of-the-line XW5 Series from Xwatch Safety Solutions. The 3D Avoidance Zone System will allow users to create or import 3D avoidance zones above and below the surface area directly within the Leica MC1 machine control software. The solution minimises downtime, reduces unforeseen costs, and provides a safer environment for machine operators and nearby workers.



## KEY BENEFITS

- Provide a safer environment for machine operators and nearby workers
- Avoid downtime & reduce unforeseen costs
- Avoid the hassle of having to deal with all the admin work and stakeholder management required when external providers' infrastructure has been struck





The operator can quickly create or use imported avoidance zones in the in-cabin display, the Leica MCP80 panel. Critical avoidance areas include overhead obstructions such as powerlines, underground services, and operations close to pedestrian walkways, live carriageways, and public roads.



When approaching an avoidance zone, the system will take control of the machine's height, depth and slew movements triggering the hydraulic functions of the excavator to stop once approaching these zones. The hydraulic control is proportional, meaning the machine's movement will slow down before completely stopping when approaching an avoidance zone. The motion of the excavator's tracks can also be disabled so it cannot breach environmental areas or designated no-go zones, even avoid overhead power cables or gantries.



Once the solution has stopped the machine, the Leica MC1 software will trigger a visual warning that needs to be acknowledged before continuing any other operation.





# Off-machine solutions

Invest in the solution you need today and have the flexibility to expand your product portfolio based on your future needs tomorrow. Maximise your investment with flexible hardware and software solutions that allow you to carry out critical positioning tasks with confidence. These on-the-ground solutions not only increase your efficiency, but your peace of mind as well.

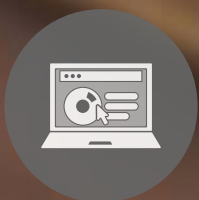

**iCON field software**



**Tablets**



**Smart Antennas**



**Robotic total stations**

# Leica iCON site – Profit from your investment



## User interface customised for construction personnel

iCON site is designed to increase your productivity and enable you to adapt to any given scenario on site. If you work with machines on site, use iCON site to check your progress to determine if you are working to the correct depth, profile, grade or surface, without having to wait for an engineer or surveyor to carry out these tasks. iCON site is developed to seamlessly integrate with any of the Leica iCON sensors and machine solutions.

Using the same, interchangeable user interface means:

- You only need to learn its functionality once resulting in less training, increased motivation and significantly reducing your investment
- The ability to exchange hardware and data between on-machine and off-machine use, projects and site personnel maximises your flexibility and reduces possible downtime

## Exceptional application functionality

The features and graphical support within iCON site allow you to carry out specific tasks on site in an easier, straightforward way. Use iCON site for checking dimensions, volumes, positions and the status of key site elements. iCON site allows the user to complete all site related tasks from one measuring device ensuring an effortless process from start to finish.

- Simply measure, stake-out or check site elements without waiting for an engineer or surveyor to do the work for you
- Benefit from quick volumes and checks by using iCON site for site navigation on your vehicle
- If using 2D machine control, iCON site allows the operator to mark out the required starting point or boundary of the profile. Utilise the application on the excavator, dozer, grader, scraper, and milling machine

# Leica iCON site for foremen – Take the **guesswork** out of your project

With the Leica iCON site field solution you can increase efficiency and quality of work on site. The Leica iCON field Supervisor and Foreman kit from Leica Geosystems gives you instant real time access to project statistics in the field, allowing you to make informed decisions quicker than ever before. Instantly increase site productivity by checking the efficiency of your machines and site personnel with an easy-to-use in-cab display, make checks on whether your project is on time, on budget and on specification. With iCON site software you can carry out accurate as-built checks, grade checking and volume calculation.

- Real-time project information and statistics in the field
- Update site personnel with new design files and work orders
- Minimise errors and avoid costly rework
- Increase machine utilisation and save fuel costs by doing the job right the first time
- Calculate the exact volume of excavated dirt or fill materials needed to optimise material savings
- Conduct simple site measurements and calibrations without waiting for a surveyor to do the work – reducing machine downtime and increasing productivity
- Navigate to points-of-interest, such as control points or site boundaries



Panasonic FZ-G2

Leica CC200



TOUGHBOOK

A1 A2 - +



# Leica iCON CC200/CC180/CC170 – Real-time communication on site

Leica iCON CC200, CC180 & CC170 are versatile tablet PC's designed to transport a user's office directly to the field. The rugged, lightweight and thin devices have a clear and easy-to-use touchscreen designed to facilitate data collection tasks on site while at the same time communicating with the central office; real-time data transfer is made easy.



## Leica iCON CC200

Reliable and robust field controller for the iCON field software with large display and increased performance. The iCON CC200 is made to smoothly handle use cases requiring large amounts of data.

### KEY FEATURES

- Large 10" screen size
- Hard keys with user-defined shortcuts
- 'Glove' and 'rain' modes for all weather conditions
- Up to 12 hours operating time
- Anti-reflective (AR) screen
- 'Portrait' mode to support specific applications



## Leica iCON CC180

A compact yet high performing field controller for the iCON field software. The handy iCON CC180 offers advanced hardware technology and is compatible with machine guidance applications.

### KEY FEATURES

- 8" high visibility screen
- Powerful processor for complex designs
- Fan-less design to reduce device-generated noises
- 'Glove', 'rain' and 'stylus' operation modes
- Robust and resilient for all weather conditions



## Leica iCON CC170

The ideal small-sized field controller, compatible with iCON field software. Its optional long-range Bluetooth® connectivity and lightweight make on-site positioning tasks simple and accessible.

### KEY FEATURES

- 7" sunlight-readable screen
- Lightweight for convenient use throughout the day
- Full-LTE support and one modem for all regions
- Optional long-range Bluetooth® module
- Hot-swappable batteries





# Leica iCON gps 160 – An unmatched return on investment

The iCON gps 160 is the ideal solution when it comes to flexibility, quality and return on investment. This versatile and reliable GNSS Smart Antenna supports multiple daily tasks (such as supporting rover, base station, vehicle and various on-machine applications). The solution stands out for its simplicity and ease of use, highly intuitive software structure and smart features. The equipment generates an unmatched return on investment for those who want to get the most out of it and reduce the downtime caused by a cumbersome setup. All in one . . . and one for all!



## KEY FEATURES

- Integrated colour display for easy and fast setup
- Rugged aluminium housing and IP66/IP68 protection for the harshest site conditions
- Latest RTK technology for fast initialization and reliability
- SmartLink Fill to bridge RTK connection signal interruptions for up to 10 minutes
- Integrated global modem
- 'Smart Get here', 'BasePilot', intuitive setup wizards and other smart features
- Optionally available with calibration-free tilt compensation
- Seamless integration into iCON field solutions



# Leica iCON gps 70 Series – Higher efficiency with construction GNSS antennas

The Leica iCON gps 70 and Leica iCON gps 70 T are GNSS rovers and field solutions for increasing efficiency. With the iCON gps 70 T you can measure and stakeout points swiftly without the need to keep the pole vertical and level the bubble. The combination of the latest GNSS technology and inertial measurement unit (IMU) equips the iCON gps 70 T with permanent tilt compensation and makes it resistant to any magnetic interference. Being fully calibration-free, the iCON gps 70 T is ready when you are – anytime, anywhere.



## PERMANENT TILT COMPENSATION

- Calibration-free
- Resistant to magnetic interferences
- Increased measurement productivity and reduction of human error

## FUTURE-PROOF GNSS TECHNOLOGY

- 555 channels for more signals, faster acquisition and improved sensitivity
- Intelligent management of multi-frequency, multi-constellation signals
- Intelligent selection to automatically reject reflected or noisy signals

## HARDWARE & ERGONOMICS

- Compact and lightweight housing
- UHF radio
- Tilt and non-tilt variant

## ROBUSTNESS FOR DEMANDING SITES

- Leica iCON CC200, CC180, & CC170 are reliable field controllers with high-quality touchscreens. Featuring various operation modes and complex design processing, they can function in any weather
- IP66/IP68 protection
- Built for extreme temperatures of -40°C to +65°C
- Fulfils toughest standards throughout the complete product lifetime
- Rugged aluminium housing

## CHECK+ & TRACK+

- Unique RTK technology provides continuous checks to guarantee correct results
- Initialisation within seconds
- Complete reliability

## ICON FIELD SOLUTION

- Seamless integration into the iCON field solution
- Easy-to-use software interface and seamless data flow throughout the workflow
- Exceptional application functionality
- Leica ConX cloud-based collaboration tool for real-time 3D data exchange

# Leica iCON gps 30 – Compact and trustworthy GNSS RTK rover for construction

Take the first step into Leica iCON construction workflows with Leica Geosystems' entry-level GNSS RTK rover. The iCON gps 30 is designed to assist construction companies move forward from traditional, to modern digital stakeout and measurement methods.

Experience faster workflows, with accurate results and higher efficiency in construction projects, such as utility or road construction. Using advanced RTK technologies the rover delivers consistently accurate and reliable positions. Integrated into the well-established and construction tailored iCON site field software, the iCON gps 30 speaks the language of construction site professionals.



- **Entry-point into Leica iCON GNSS performance:** Easy to use and equipped with the construction tailored Leica iCON site field software, the iCON gps 30 facilitates your entry into the Leica iCON GNSS portfolio.
- **Lightest pole weight:** The light, compact and balanced design makes it comfortable to use and carry in the field.
- **Reliable and accurate measurement results:** With the highest level of position reliability in its class, the iCON gps 30 delivers accurate results and increases productivity.

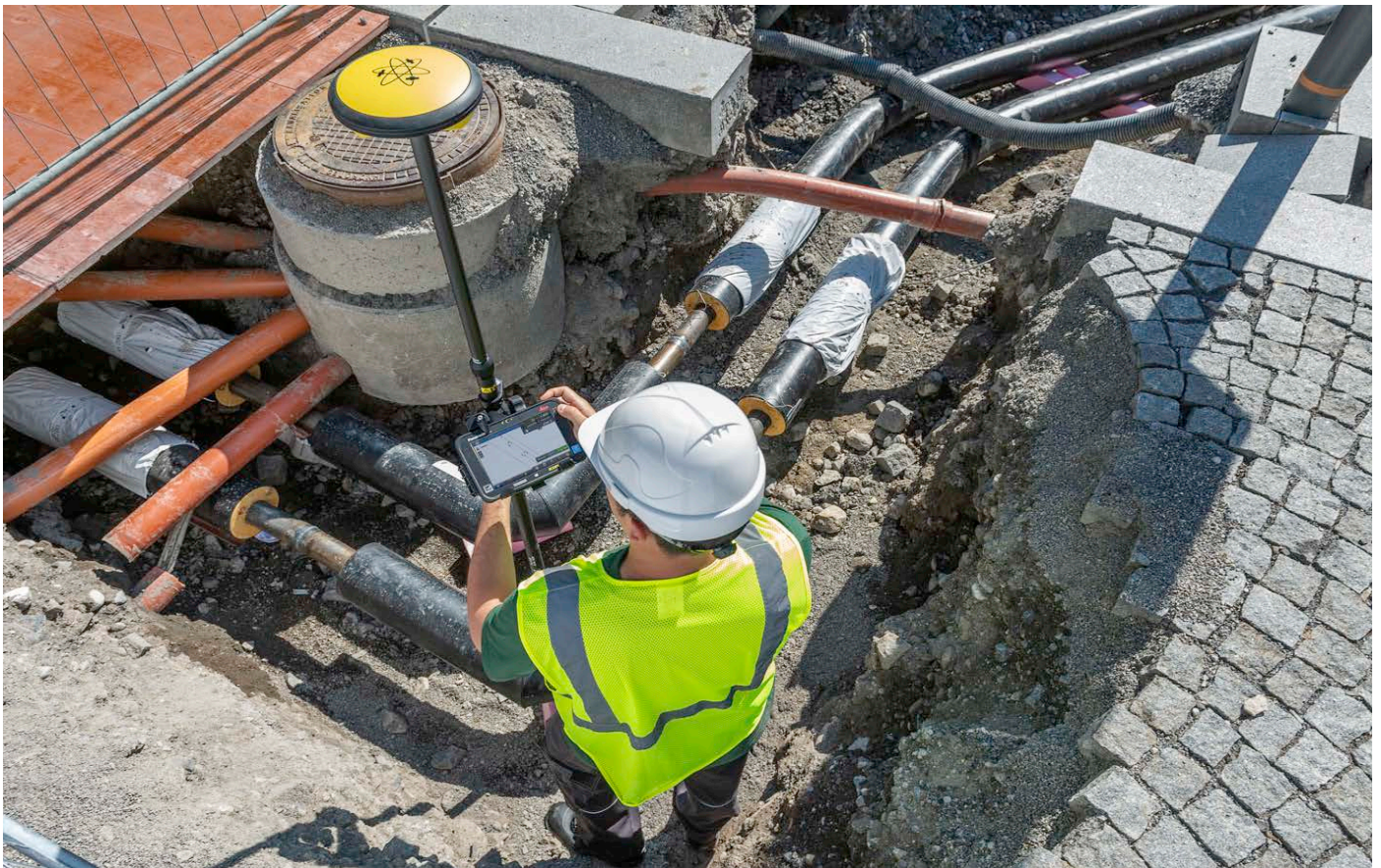

# Leica iCON iCR80 – High performance total station for **one-person operation**

Save time and increase your productivity by doing layout work and as-built checks yourself. With the iCON iCR80 you don't need an operator at the instrument. The robotic total station can be operated from the machine or the field controller at the prism pole, at the point you need positioning.





#### KEY FEATURES

- Faster prism search by patented technology, PowerSearch
- Stable data communication with long-range Bluetooth® (up to 400 m)
- Easy hand-over control from pole to machine and vice versa
- ATRplus technology, maximising the total station's ability to remain locked onto your machine mounted prism
- "Tune out targets" feature to ignore other distractions in the field
- Fastest re-lock in case of interrupted line of sight

#### KEY BENEFITS

- Obtain the highest accuracy for machine control of a wide variety of construction machines, such as curb and gutter or milling machines, asphalt or concrete pavers, and graders and dozers
- Use iCR80 for machine control of construction machines when working inside tunnels or where GNSS coverage is weak or not available
- Work with multiple iCR80 total stations for automatic leap frogging of paving machine for continuous paving and increased surface quality
- Use iCR80 for as-built documentation

## Leica iCON iCR80

The Leica iCON iCR80 construction total station keeps its 'eye' on only one thing: the user's target. Move or place more material per day thanks to ATRplus, the most robust automated-aiming, lock and re-lock technology in the market. iCR80 is especially useful in congested sites with many distractions, such as reflections, machines and people moving around. Challenging and changing site conditions should not be an obstacle.

The iCON iCR80 guarantees efficiency with the most reliable, simple and automatic set up procedure and industry-leading prism lock. This sophisticated, one-person total station offers an 'all-in-one' solution for every purpose – especially the difficult ones, allowing you to speed up your workflow.

# Leica AP20 AutoPole – Enhanced workflow and precision

The Leica AP20 AutoPole is a revolutionary smart system for Leica robotic total stations that is easy to use and enhances the digital construction workflows of Leica iCON field software with seamless integration. It resolves critical challenges construction professionals experience daily with the total station operation and delivers a true digital construction workflow by removing the last analogue step in the process, the pole. The AP20 AutoPole brings precision and productivity gains to different construction phases, with unique target search and identification, automatic pole height readings and updates in the field software and pole tilt compensation.





### TargetID

TargetID enables the total station to identify your target on the fly during search. Maintain prism lock, increase operative time on the pole and be unstoppable with your Leica iCON construction robotic total stations.

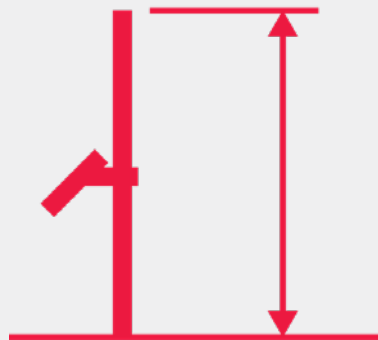

### PoleHeight

The PoleHeight feature of the AP20 AutoPole automatically updates the correct pole height within the iCON field software every time you adjust your pole height. When working with 3D design data or recording as-builts, be confident that every measurement is correct when moving around busy sites.

### Tilt Compensation

Work smarter, not harder. The AP20 AutoPole tilt compensation provides flexibility to measure or layout points without the need to level the pole. Boost productivity by doing more and also in previously challenging areas without sacrificing project standards, as all quality information is available and recorded.

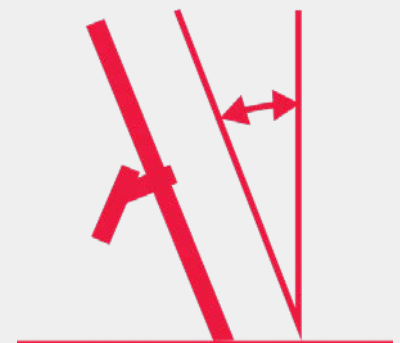

# On-machine solutions

Increase accuracy, productivity, and uptime with Leica Geosystems' machine control solutions. With a powerful feature set and real-time designs sent straight to the machine, avoid rework, material waste, and reduce crews needed on site – meaning a safer work zone.

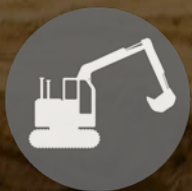

Excavator solution



Dozer solution



Grader solution



Wheel loader solution



Driller solution





**Piler solution**



**Compaction solution**



**Asphalt paver solution**

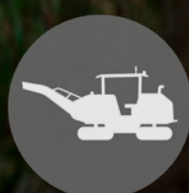

**Milling solution**



**Concrete paver solution**

# Leica MCP80 and MC1 – One panel, one software, **always connected**

The Leica MCP80 can handle all 3D applications in heavy construction. You can easily move your panel from machine to machine no matter the application. The Leica MDS series in-cabin docking stations will store your calibration values and hydraulic parameters for worry-free machine swapping. These docking stations require no long-winded setups when switching panels. And at an IP67 rating, these are truly the most resilient docking stations for the heavy construction industry.



## One for all

Digitalise your construction site with one software and one hardware platform. Switch from one machine to another and build complex designs with simpler workflows and less downtime.



## Easy to use

Simple, clean and intuitive user interface with interactive user design adapted to your needs. The assistive technology with wizards and help functions help you drive the machine and get more work done with high quality and less rework.



## Robust design

With robust design the Leica MCP80 panel and the Leica MDS series docking station are prepared for the harshest environment and are truly resilient for the heavy construction industry.

# Leica MCP80 – One panel, complete control



MCP80 is available for:



Excavator



Dozer



Grader



Wheel loader



Driller



Piler



Compaction



Asphalt paver



Miller



Concrete paver

## One common platform

### Optimising the machine fleet

Leica Geosystems delivers an intelligent and intuitive hardware and software combination for the heavy construction industry. The all-in-one machine control platform consists of the Leica MCP80 panel, a docking station, and the Leica MC1 software, which supports multiple machines and applications.

Simplified and connected solutions for increasing staff productivity on site and unifying design data for seamless workflows are essential to keep margin gains and generate profits. With the all-in-one machine control platform, Leica Geosystems delivers a unique, intelligent and intuitive hardware and software combination for the heavy construction industry.

Leica Geosystems' solution for heavy construction applications offers a unified hardware platform with common software interface across our machine control portfolio. Interchangeable between several heavy construction machines, the Leica MCP80 control unit integrates into the common software platform, Leica MC1, while Leica ConX, the cloud-based and user-friendly productivity platform for increased project efficiency, rounds off Leica Geosystems' goal to achieve a digitised construction site.

### KEY FEATURES

- Fully cable-free
- Easy panel removal in the cab
- IP67 environmental rating
- One common interface across all 3D machine control applications
- Simple and intuitive user interface
- Easy installation and quick setup for operators
- Rugged design of cradle and panel
- Docking station with onboard memory
- One software for all for faster and uncomplicated operations

# Leica iCON MCP70 & MCP50 2D panels – Smart technology in a simple form

The 7" and 5" modern Leica iCON MCP70 and MCP50 machine control panels are both compact and lightweight, offering portability and convenience. Both panels feature a bright multi-touch screen display, providing customers with excellent visibility regardless of the time of day or lighting conditions. These panels are compact HMI devices that are easy to configure and ideal for high-quality machine design. The high sensitivity and accuracy of the projected capacitive touch screen improve customers' usability on the construction site.





#### KEY FEATURES

- Available in two different sizes. Pick the one that best fits your needs and requirements
- Lightweight and easy to carry on-site
- Rapid interchange of control panels between machines
- Multi-touch screen functionality
- Easy removal of core components for overnight security

2D panel is available for:



Excavator



Dozer



Grader

# Leica iCON gps 120 – Machine Smart Antenna

The Leica iCON gps 120 Machine Smart Antenna is part of Leica Geosystems' advanced heavy construction solutions, offering versatility and flexibility for construction projects that require cutting-edge technologies. It is integrated into the advanced Leica MC1 machine control system, easy to install on various construction machinery. The iCON gps 120 is built to withstand the harsh conditions on construction sites, ensuring durability and long-term performance.

A key benefit of the iCON gps 120 is its scalability. Customers can start with a single GNSS solution using a satellite-based augmentation system (SBAS) or HxGN SmartNet PPP service. Once they need to advance their systems to higher specifications, they can easily upgrade to an RTK solution with low or high accuracy by adding the communication unit Leica CR50. With a second iCON gps 120 Machine Smart Antenna, customers get a full high-accuracy dual GNSS solution with heading. Moreover, the antennas can be easily switched between Leica MC1 prepared machines, thanks to the easy mounting and dismounting, such as the quick disconnect system.



## KEY BENEFITS

- Easy and cost-efficient upgrade to a higher specification solution.
- Scalable Leica MC1 configurations
- Multiple and easy antenna mounting options
- Web interface for convenient access for configuration and software updates
- Future-proof GNSS technology that supports all constellations & frequencies
- Seamless integration into iCON field solutions

# Leica iCON aps 200, gps 120, gps 100 & CR50 – Machine control GNSS receivers

The Leica iCON portfolio for construction offers a variety of hardware and software tailored to meet your specific business needs and application requirements. Key components of this suite – Leica iCON gps 120, Leica iCON aps 200, Leica iCON gps 100, and Leica CR50 – are GNSS machine receivers that form an integral part of the Leica machine control solutions. Each GNSS receiver embodies distinctive hardware and firmware traits, offering customers the flexibility of choice. All the Leica iCON GNSS receivers support GPS, GLONASS, Galileo and BeiDou frequencies.



## Leica iCON aps 200

### KEY FEATURES

- Web interface for convenient access for configuration and software updates
- Continuous GNSS signal availability, even when the primary antenna is blocked
- Customers can easily change between 400 MHz and 900 MHz (US/CAN only)
- Up to 100 Hz position update rate



## Leica iCON gps 120

### KEY FEATURES

- Supporting 555 channels
- HxGN SmartNet PPP service optionally available
- Short-range Bluetooth®
- Two M12 automotive ethernet communication ports
- 20 Hz position update rate



## Leica iCON gps 100

### KEY FEATURES

- Dual frequency
- SmartLink Fill service optionally available
- Web interface for remote access
- Bluetooth®



## Leica CR50

### KEY FEATURES

- Communication unit with an internal cellular modem
- Dual-frequency radio
- Web interface for remote access
- Bluetooth®
- 2 x M12 automotive Ethernet communication ports





# Excavator solutions

From simple slope grading, to blind and submerged cuts, and everything in between, our versatile machine control solutions provide your excavator operators with design models right in the cab. The easy-to-operate user interface means your operators can jump on it with little training and get optimal results. Grade check without a surveyor with our robotic total station guidance or our GNSS setup for advanced control. And at the end of the day, the core components snap off for maximum security.



## Leica iCON iXE2

Our 2D solution gives the operator high-accuracy dual slope and level control for maximum utilisation of your machine from the start.



## iCON site excavator

The simple solution for compact excavators brings a higher level of efficiency to small to medium sized excavators in the fleet.



## Leica iCON iXE3

For those who need the ultimate precision guidance, the 3D machine control solution is available. Work from 2D and/or 3D digital models for supreme accuracy and the most complex designs.

# Semi-automatic excavator – Increase your uptime

The semi-automatic functionality for Leica iXE2/iXE3 excavator machine control solutions helps the operator to perform complex fine grading jobs faster and more accurately by **automating the movements of the boom, bucket, tilt bucket and tilt rotator functions**. The semi-automatic excavator is a flexible solution, and the operator can easily switch between manual and auto mode to ensure maximum safety.

## KEY FEATURES

- The design slopes are followed automatically only by operating the stick
- Intelligent slope detection with closest cross slope
- Surface protection (no tool point digs into you surface)
- Rotation control cross-cut
- Stick enabling (no push and hold on the button)
- Easy to switch between manual and the auto function with manual control when required

## KEY BENEFITS

- Less operator fatigue
- The job can be done faster because costly and time-consuming rework can be avoided
- Consistent quality of finished surface
- The semi-automatic functionality from Leica Geosystems is safe to use
- Flexible configurations to suit any use case and machine configuration



# Automating excavator functionalities



## iXE CoPilot

Using the Leica iXE CoPilot, the excavator operator only needs to concentrate on controlling the digging movement (boom, stick, and bucket), while the tilt and rotation function of the tilt rotator are adjusted automatically based on the reference model surface under the bucket.

The operator maintains control of the bucket rotation, allowing him to manage the material in the bucket properly while eliminating the constant manual adjustment of the slope of the bucket. Enabling the CoPilot by simply pressing a button simplifies the use of tilt rotators regardless of training level, reducing operator fatigue.

## Automatic Tool Recognition

Use tool recognition to automatically select the right tool for your excavator. Tool recognition modules are mounted on the excavator buckets and tilt rotators. The hub in the cabin registers and sends signals to the machine control solution when the bucket is taken off, or a new bucket is selected. It also sends warnings if a bucket that is not calibrated is selected. Thus, the operator no longer needs to manually change settings when changing work tools.

This minimises the risk of using the wrong bucket and the subsequent over or under-digging and costly rework. Besides supporting the attached tools, the tool recognition system also supports standard tilt buckets and detachable tilt rotators.



# Leica iCON iXE3 – The future of excavating

The iXE3 machine control solution guides the operator using reference models and GNSS in 3D. Design information and real-time cut/fill indications are displayed in the cab on your control panel, allowing you to rapidly excavate to the reference design. The solution ensures more uptime and operator satisfaction while increasing safety and productivity.

Work with a wide range of popular data formats including LandXML, DXF, GEO, KOF, L3D, LMD, LIN, MBS and TRM formats. The operator can use the function Create Model to make even complex models directly on the panel without leaving the cab and without the assistance of a surveying engineer. Leica MC1 ensures a live digital representation of the operators work. Follow the progress made while digging on the run screen, as model modifications are made with tool point interaction.



## One for all

Digitise your construction site with one software and one hardware platform. Switch from one machine to another and build complex designs with simpler workflows and less downtime.



## Easy to use

The simple, clean and intuitive interface adapts to your needs. The assistive technology with wizards and help functions help you drive the excavator and get more work done with high quality and less rework.



## Robust design

The Leica MCP80 machine control panel and Leica MDS series docking station are designed to operate in the harshest environments and deliver high performance to the heavy construction industry.

# Excavator 3D solution – Get full control of your excavator

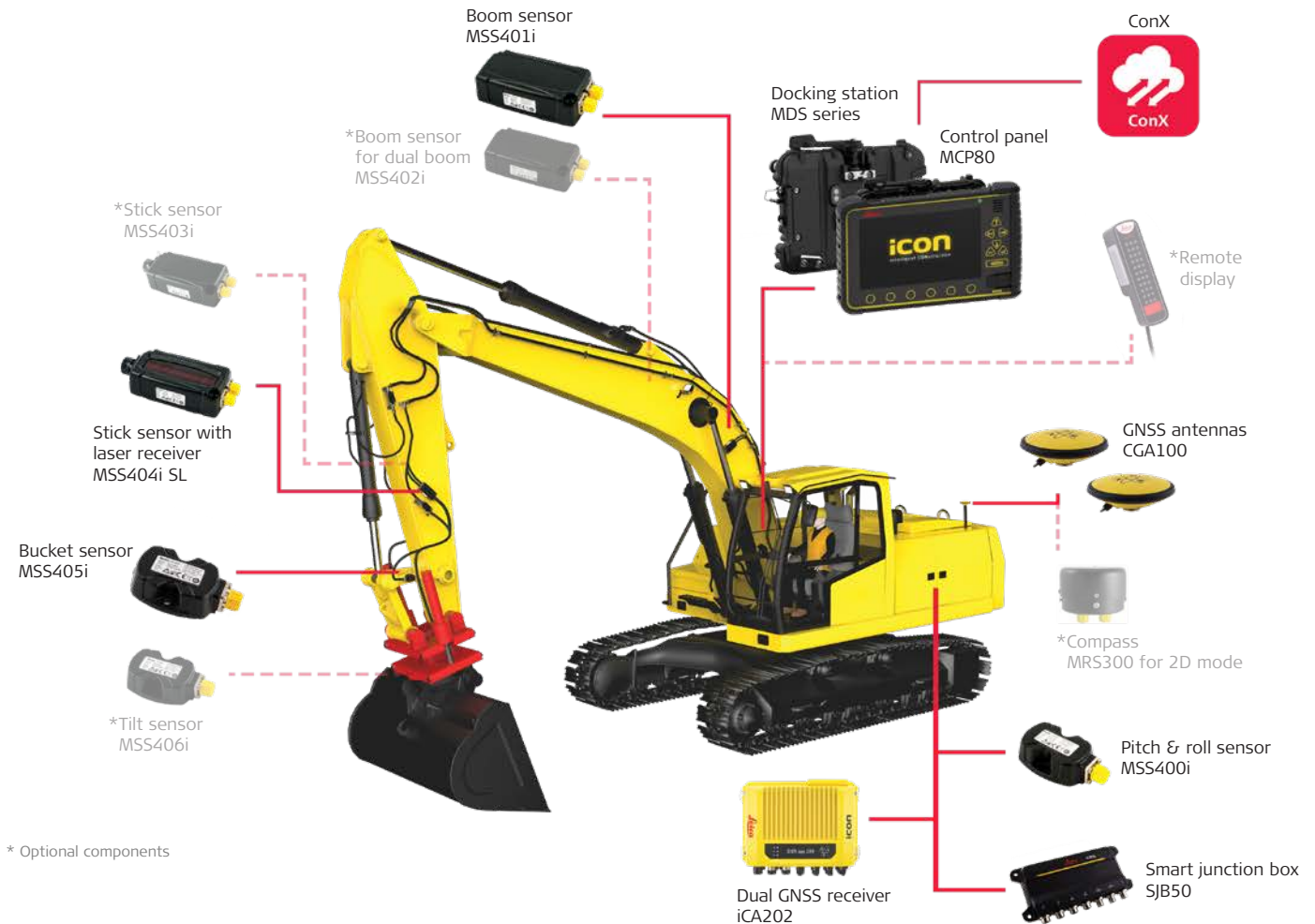

## One panel

The MCP80 panel can handle and be used in all 3D applications in the heavy construction industry. The easy-to-use industry-leading panel features a large touchscreen display with backlit buttons. The MDS series docking station stores your latest calibration values and hydraulic parameters. Its cable-free design makes docking station removal and panel swapping easy, allowing you to quickly move the MCP80 from one machine to another.

## One user interface

One software platform for all machines with a simple and intuitive user interface. Simply turn the key and get on with your work. The interactions support the workflow of the task at hand, and the clean interface makes it easy to find the functions you need using icons for fast navigation. The assistive technology with wizards and help functions enable you to get more work done with higher quality and fewer errors.

## Other available options:



Single & Dual GNSS configuration with iCG120 & CR50



Prism & compass configuration



# Leica iCON iXE3 – For compact excavators with swing boom

Add machine control to mini excavators with swing boom, and benefit from all the advantages of our advanced machine control such as higher accuracy, digital workflows and as-built documentation.

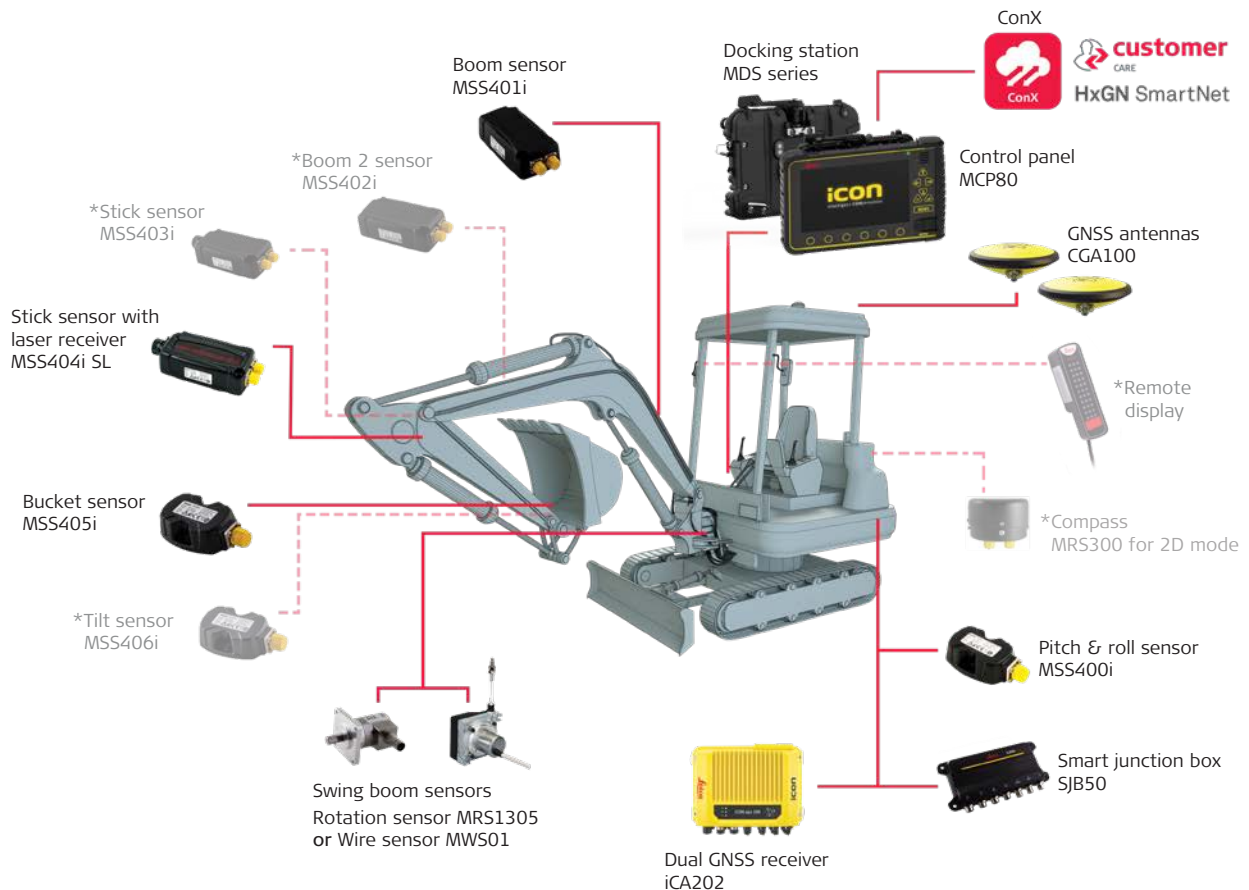

## Other available options:



a) Single & Dual GNSS configuration with iCG120 & CR50



b) Prism & TPS configuration

c) Manually defined angles of swing boom (no swing boom sensor)



## KEY BENEFITS

- Swing boom sensor or manual support of swing boom
- Same software and hardware platform as other Leica machine control applications
- Digital workflows available for mini excavators and backhoes
- ConX integration for data sharing, as-built documentation and remote communication

# Machine control – For the compact excavators in your fleet

Expand the machine control offering to include your little expert of trenching and excavating jobs, and benefit from all the advantages of 3D machine control: higher accuracy work, avoid over-digging, rework and fewer errors, one common software and hardware platform with similar menus and workflow across application. Key hardware components can be moved on different machine applications, possibility for digital logging and reporting as as-built documentation through the use of ConX.



## High accuracy machine control for compact excavators

Compact excavators and Huddig backhoes with swing boom are designed for trenching and excavating in areas where larger equipment can't operate. The machine's swing boom moves independently, so you can dig alongside obstacles with better visibility. Leica Geosystems offers a flexible solution with swing boom sensor or manual calculation of the position of the swing boom.



Select swing boom type



Select swing boom position



Run screen for excavator with swing boom

# Leica iCON site excavator – The best way to get started with machine control is here

The Leica iCON site excavator is a simple, easy-to-use machine control solution for optimising the earthmoving jobs of compact excavators. This solution integrates easily with the existing iCON site applications, so you can benefit from efficient workflows. Measure an area, create a design, and then directly dig according to that design by simply using the same field controller in the excavator cab.





# Extreme simplicity – Design it. Dig it. Check it.

Achieve optimal on-site flexibility and efficiency along with independence from surveyors and their schedules - all with a solution that is incredibly easy to set up and use.

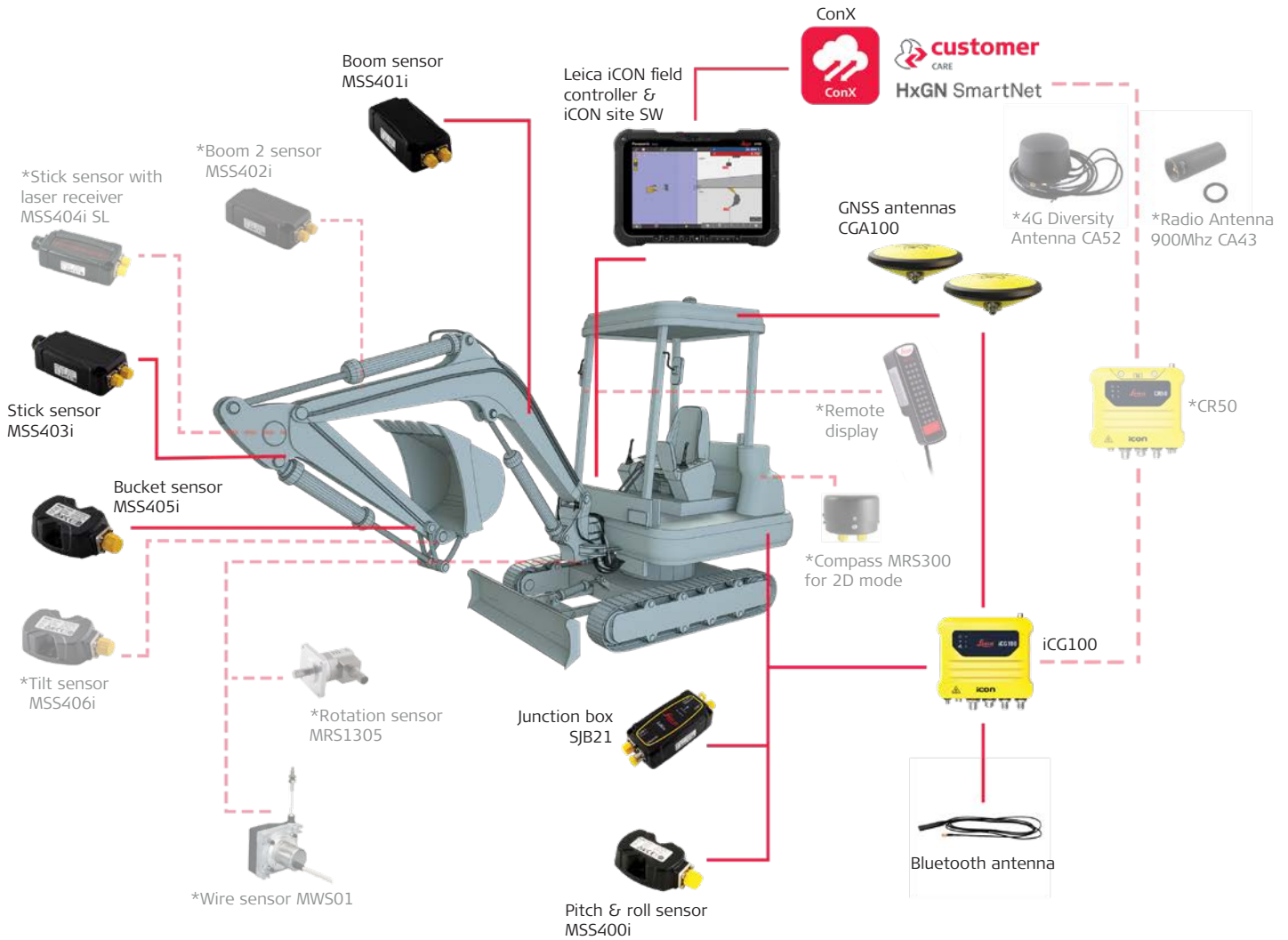

## KEY FEATURES

- Supports swing boom, tilt rotator and tilt bucket functionalities
- Map-driven selection and navigation
- Traffic-light indication of work results
- Split-screen functionality that allows different user interface viewing perspectives
- Use the same digital designs as the big machines in the project ecosystem
- Integration with Leica ConX to ensure seamless communication of design updates

## Other available options:

Manually defined angles of swing boom (no swing boom sensor)

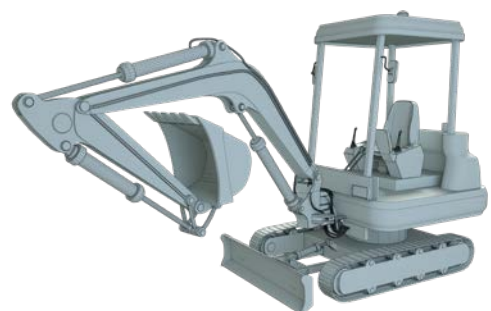

# Leica iCON iXE2 – Single/dual slope and depth control

Built to make excavating tasks easier, our multifunctional 2D machine control system is designed to support and boost your productivity on the construction site. It allows multiple elevations and slopes to be constructed at any orientation without resetting the machine or laser height reference.



# Excavator 2D solution

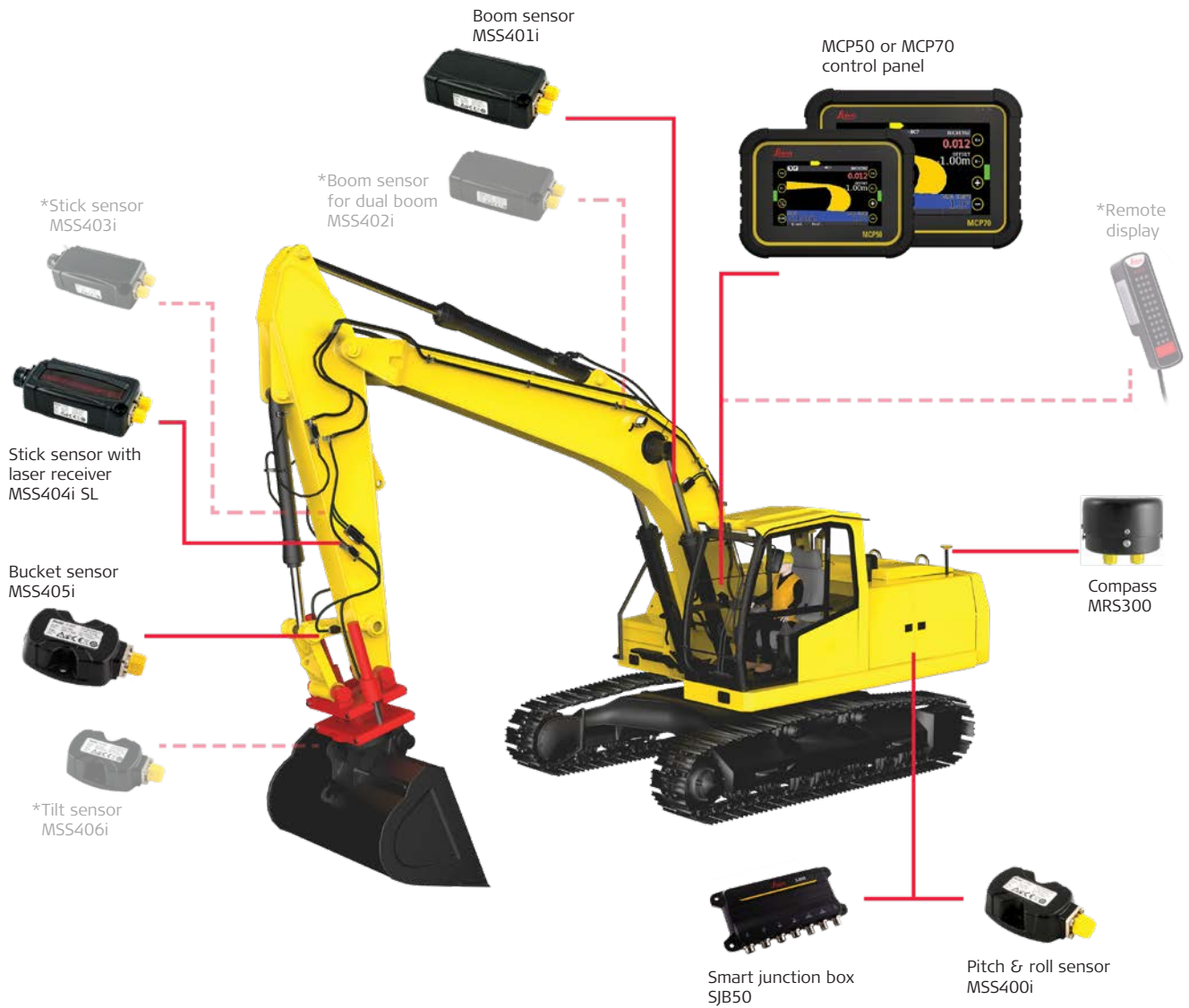

## iXE2 – Simple and smart

The Leica iCON iXE2 displays the bucket's actual position relative to design elevation and slope, so you can reach the design grade faster when working.

Feel the power of more control and efficiency when excavating. Our 2D excavator solution aims to streamline excavation duties and intensify productivity, enabling the establishment of multiple elevations and slopes at any orientation without having to reset the machine or laser height reference points.

### KEY BENEFITS

- Upgrade to 3D by adding a GNSS receiver and 3D control panel.
- High-accuracy dual slope and level control via the rotation sensor
- Real-time cut/fill indication on the graphic display
- No grade checking needed
- No more over excavations

# Submersible configuration – Smart Underwater excavating

The Leica MSS420i sensors used for underwater dredging jobs are built on the well-established MSS400i Series Sensor technology. Ensuring speed, performance, precision, and productivity (SP), the MSS400i Series Sensors with the SP Technology allows faster digging without loss of precision at higher speeds. Together with Leica MC1 software and Modify Models, dredging operators can now establish a live digital representation of their work on the MC1 run screen, dramatically increasing machine utilisation and productivity.



## Reinforced cabling, sensor housing and bracket

Designed to be used down to 40 m at 5 bar pressure, the MSS420 sensors are equipped with reinforced components such as pressure tight connectors, a robust sensor housing, rugged cabling and stainless-steel brackets making it the most reliable equipment for underwater applications. The Leica MSS420 dredging sensors can be programmed to boom 1, boom 2, stick, bucket and even tilt sensors.

## Modify models, advancing dredging excavators

Leica MC1 software and Modify models are the ultimate feature for dredging productions. It provides a graphic representation of the progress made by the excavator-based dredging machine, visualising the bucket and position below the water surface on the MC1 run screen. The logged model gets modified with tool point interaction, allowing for a live progress update on the panel while working.





# Dozer solution

With our machine control solution for dozers, you can tackle any task from small road jobs and creation of parking lots, to large industrial sites or highways projects. Our solutions give the operator proficiency with little training and an easy-to-use yet powerful interface. Choose the entry-level 1D solution with CoPilot that offers you automatic blade control or pair our flexible solutions with a rotating laser, total station, or GNSS to tailor to your needs, and optimise your productivity and workflow on site. Core components can easily be dismantled and reused in other machine control configurations.



## Leica iCON iGD1

Our entry-level machine control solution allows operators to set a desired slope/grade reference, and automatically hold that slope/grade without the need for lasers, masts or GNSS.



## Leica iCON iGD2

An easy to use dozer machine control solution that will grant you with powerful control over your machine. Work with a variety of different sensors and simplify your tasks.

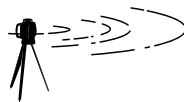

## Leica iCON iGD3

The elite 3D machine control solution for your dozer. The Leica MC1 software gives you the ultimate accurate and independent control, anywhere on the project design. Empowering you with advanced technology to automate on-site grading.

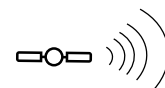

# Leica iCON iGD3 – Intelligent 3D grading solution for dozers

Open new dimensions in earthmoving and fine grading with our Leica iCON iGD3 dozer solution. It brings the design surfaces and alignments inside the cab. Work independently and accurately anywhere on the project design, guided by GNSS or total station. Choose between single and dual GNSS or a TPS solution when even tighter accuracy is required.

With Leica MC1 software on your control panel in the dozer cab, you can receive a live digital representation of your progress on the logged surface model on the run screen, modified with tool point interaction. The solution's interface with Leica ConX makes easy data transfer between offices and machines, remote communication, fleet management, and earthmoving productivity analysis via the cloud-based ConX website.



## KEY BENEFITS

- User-selectable views (e.g. Plan View, Cut & Fill View)
- Visible display screen, even in direct sunlight
- iGD3 remembers all your settings
- Scalable from 1D and 2D to full 3D machine control capability
- Create a reference surface with up to four slopes



# Dozer 3D solution

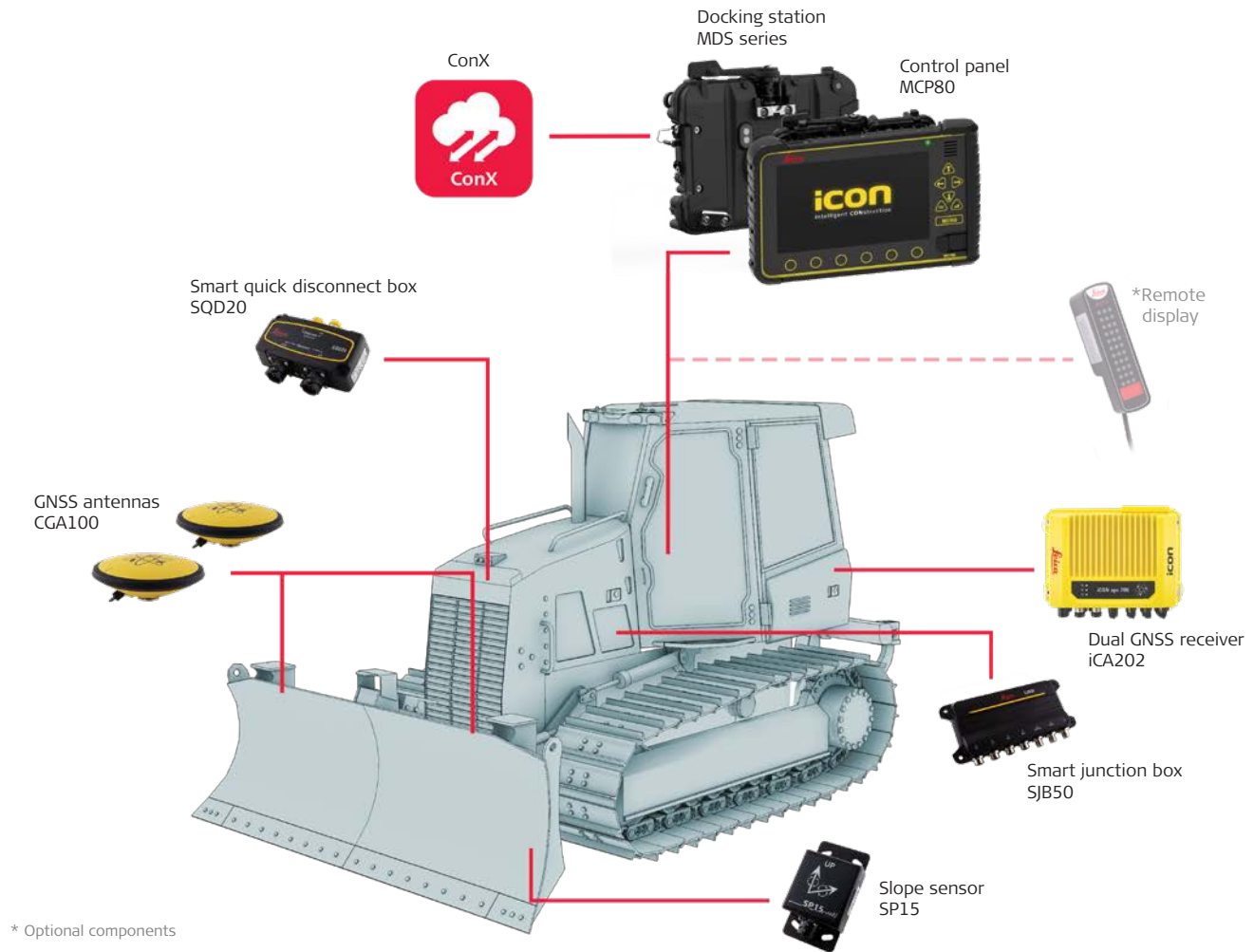

## Other available options:



Dual GNSS on-cab configuration with iCG120 & CR50



On-cab configuration



Single GNSS configuration with iCG81



Prism configuration

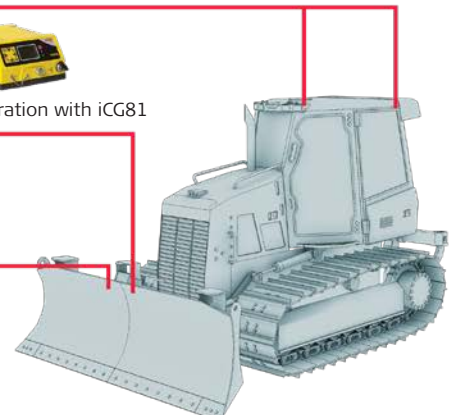

## Leica iCON iGD3

The Leica iCON grade iGD3 solution can dramatically increase machine utilisation and productivity and optimise material usage on any earthmoving and fine-grading contract. Configure your machine with single or dual GNSS or use a TPS configuration to obtain even higher accuracy.

## Intuitive user interface

The common software platform, Leica MC1, offers a clean and simple design with all relevant functions made easily accessible directly in the run screen. Modify and select different run screen views to fit your needs and the requirements of the job site.

# On-Cab configuration – with 6-way blade support

The iGD3 dual GNSS solution is optionally available with on-cab mounted antennas. Our 6-way blade on-cab configuration supports front and rear or left and right mounted antennas to create a flexible solution and mount that fits your wishes. This configuration means the antennas are roof-mounted on the cabin, not the dozer blade. The big advantage is that there are no external masts and cables, which gives the operator better visibility, advanced personnel safety and reduced wear and tear of the equipment. Control the full range of movement of a 6-way blade attachment with the latest version of Leica MC1 and the revolutionary positioning technology of SP15 sensors.



## KEY BENEFITS

- No need to climb onto the blade for installation
- Increased field of view for the operator
- Eliminated risk of damage on masts, cables and antennas
- Front, rear and left and right mounted antennas - fit the mount to your needs
- 6-way blade support

# Leica iCON iGD2 – Easy-to-use, yet **powerful** 2D dozer machine control

Make dozer tasks uncomplicated with more automation when you are operating. The Leica iCON iGD2 dozer solution provides your dozer with automatic control of both slope and elevation. When using two masts and laser sensors, you can work independently of slope direction. iCON iGD2 can be used with a wide range of sensors and can easily be upgraded to a 3D solution, reusing the 2D sensors and components.



## KEY BENEFITS

- Dedicated grade and slope adjustment keys
- Intuitive graphics that shows the blade's actual position
- Quick and easy setup for operator preferences
- Auto or manual control mode selection

# Leica iGD1 CoPilot – Automatic cut/fill control on your dozer

The Leica iGD1 CoPilot configuration allows the dozer operator to grade to specification, regardless of their training level. It automatically adjusts critical parameters for more accurate grading results. Make straight, smooth passes without any waves on all your grading or material moving tasks.



## KEY BENEFITS

- Ensures correct grades without washboard surfaces
- Works without a rotating laser, total station, or GNSS
- Less rework, wear and tear, and training effort
- Provides a safer work environment

# Dozer 1D and 2D solutions

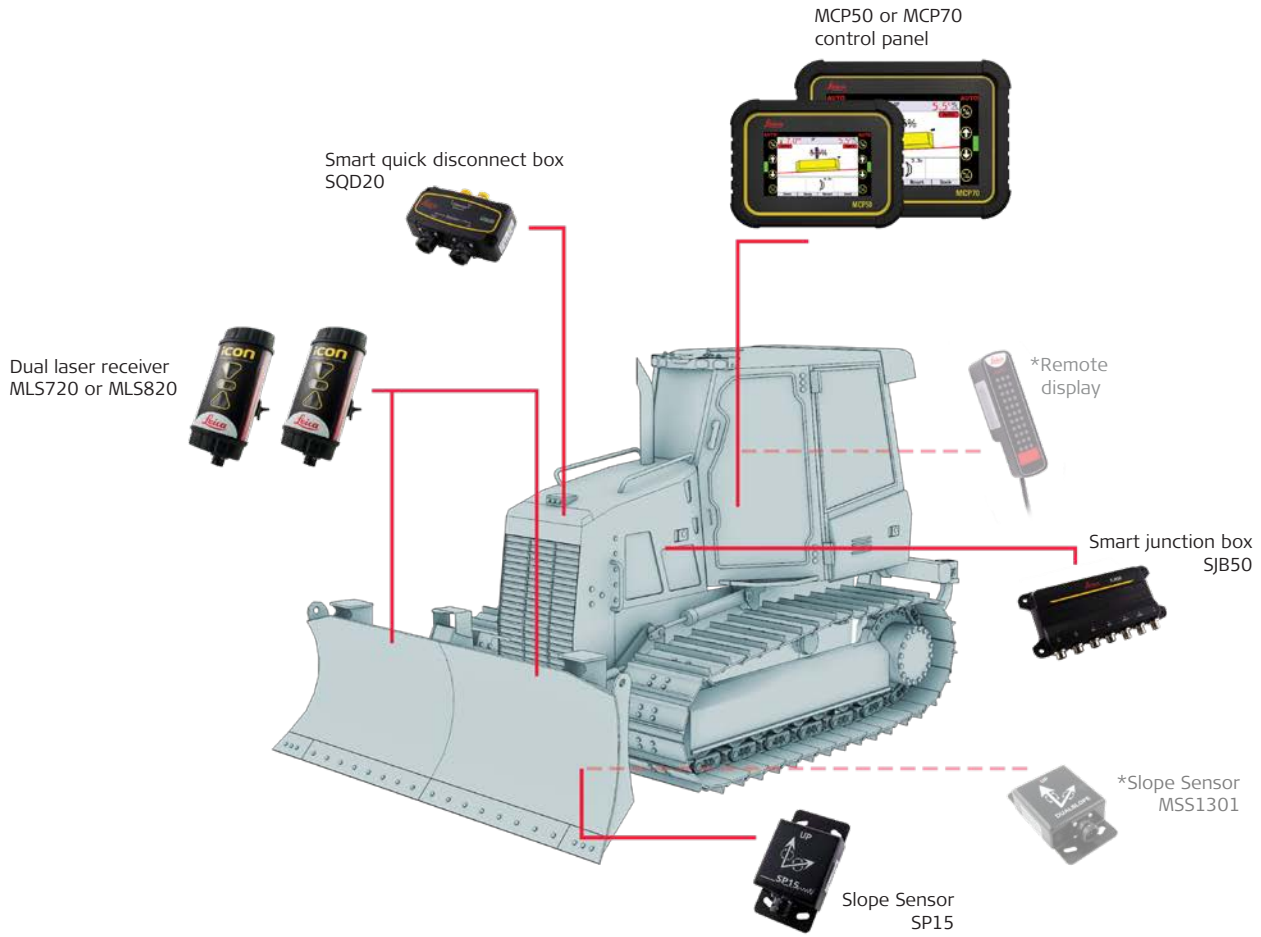

## Other available options:



Single laser receiver configuration



CoPilot configuration

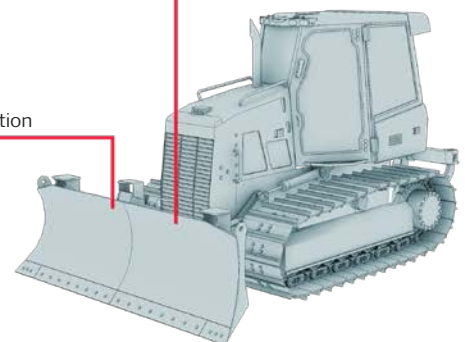

## Automatic functions

### AUTOMATIC TILT FUNCTION

Stay in permanent control of the dozer blade. The MSS1301 inclinometer sensor is mounted on the machine to detect the tilt of the blade.

### AUTOMATIC HEIGHT FUNCTION

The MLS720 or MLS820 laser sensors receive the rotating beam of laser light and indicate its position as it strikes the sensor. This information is then transferred electronically to the control panel for machine control guidance. The iGD2 can be installed with either single or dual laser receivers.



Leica Geosystems

936

# Grader solution

When using your grader for any application from cutting ditches to grading side slopes, our machine control solutions for motor graders are at your service. With an easy-to-use, easy-to-learn interface, your operators will work directly from 3D design models right inside the cab. Real-time cut and fill information means fewer passes, less rework, and no surveyor needed to check grade. When you're done, swap your components to another machine or put them away for safety.



## Leica iCON iGG2

Our 2D solution for motor graders is the perfect entry point for those looking to get into machine control. Get right to grade the first time.

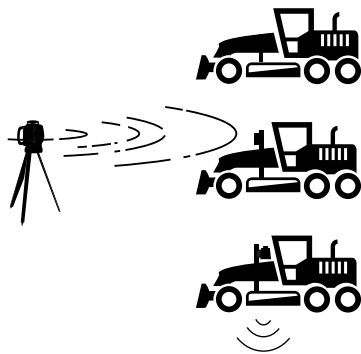

## Leica iCON iGG3

Get better insight into your job when you can work from the digital design surfaces and alignments right inside the cab. The perfect solutions for all grading applications.

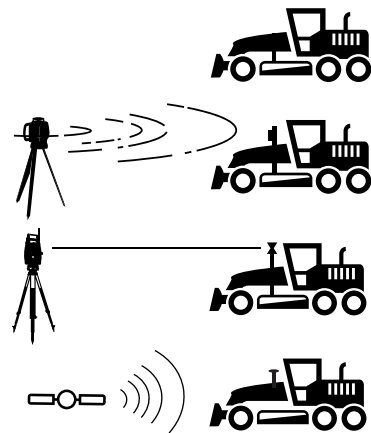

# Leica iCON iGG3 – Efficient and flexible solution

Let operators utilise the true potential of their machines for a wider range of applications, by moving materials in any way they want. Get a live visualisation of the progress made of logged surface on the MC1 run screen, which allows for modification with tool point interaction. Operators can now finish jobs faster and farther accurately, with drastically reduced downtime and complete more tasks with their motor grader than ever before.

The single or dual GNSS solutions for guided or automatic machine control for motor graders give the operator a huge range of configurations to fulfil any customer need. Use the TPS configuration to obtain even tighter accuracy.



## KEY BENEFITS

- Auto or Manual information directly on screen
- User definable views (e.g., Plan View and Cut & Fill View)
- Visible display screen, even in sunlight
- Expand your system simply by adding components



# Grader 3D solution

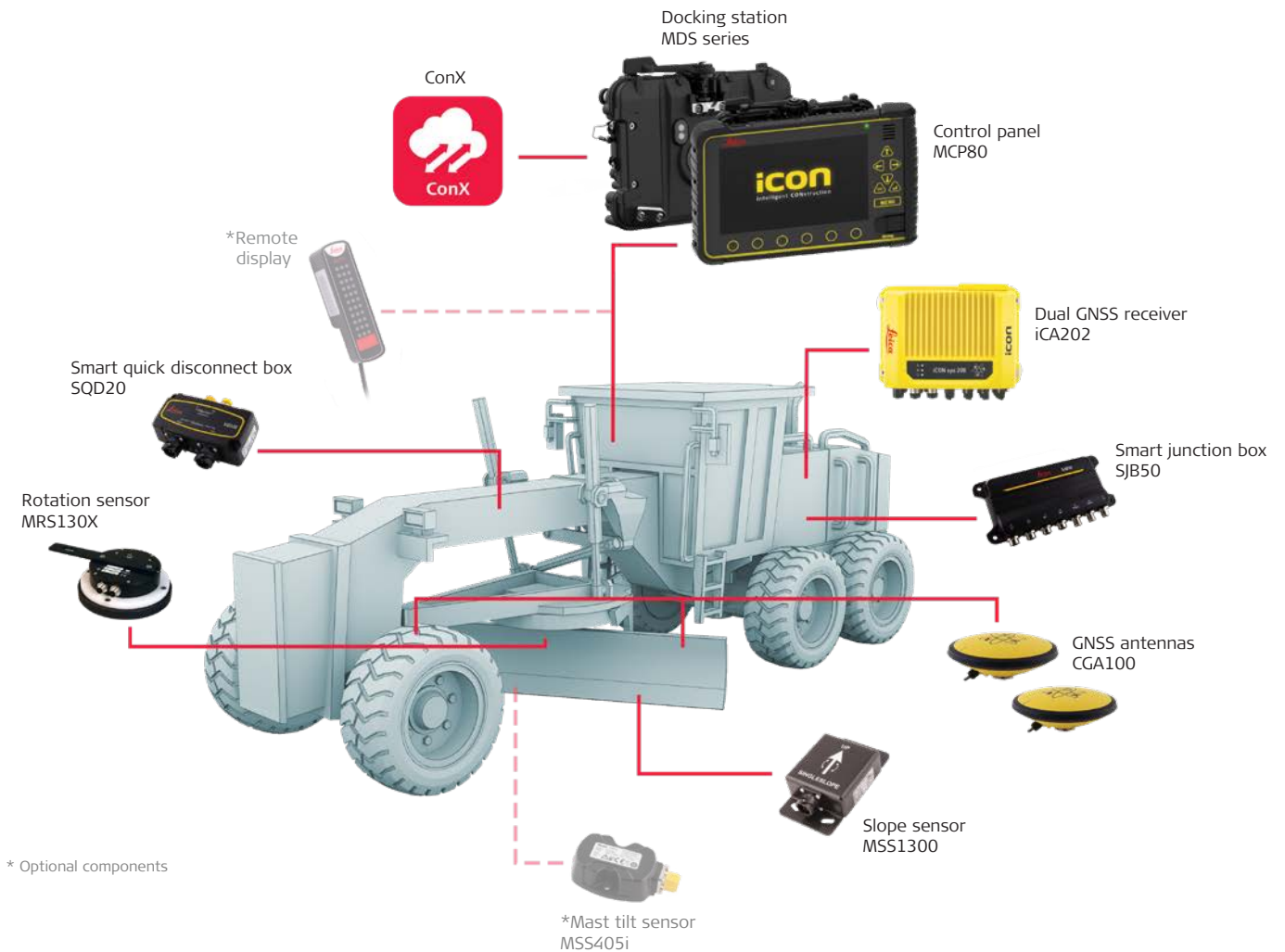

## Leica iCON iGG3 single GNSS

Optimise material usage on any earthmoving and fine-grading contract with the iGG3. Bring the design surfaces and alignments virtually in the cab – breaking you free from stakes or hubs.

## Leica iCON iGG3 dual GNSS/TPS

Our 3D machine control solution for motor graders automatically controls the blade while you focus on placing the machine in the optimal position. It controls both ends of the blade for you so you can focus on manoeuvring. Choose the TPS configuration for millimetre-accuracy control of the blade, which is ideal for fine grading applications.

### Other available options:



Single GNSS configuration with iCG81



Prism configuration

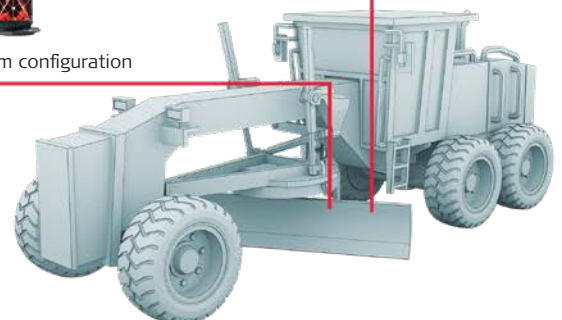

# Leica iCON iGG2 – Scalable 2D entry solution

The iGG2 solution for graders provides automatic control of both slope and elevation. When using two masts and laser sensors, you can work independently of slope direction and get to the grade faster than before. The trisonic sensor follows a curb or a stringline and integrates with the hydraulic control of the motor grader for automatic side shift of the grader blade.



## KEY BENEFITS

- Easy-to-use graphical display – the same panel is used on your 2D dozers and graders, giving you the ultimate in equipment flexibility
- Short learning curve thanks to intuitive software
- Automatic side shift from trisonic sensor
- The wireless panel (3D solution) makes it easy to place and remove from the cabin

# Grader 2D solution

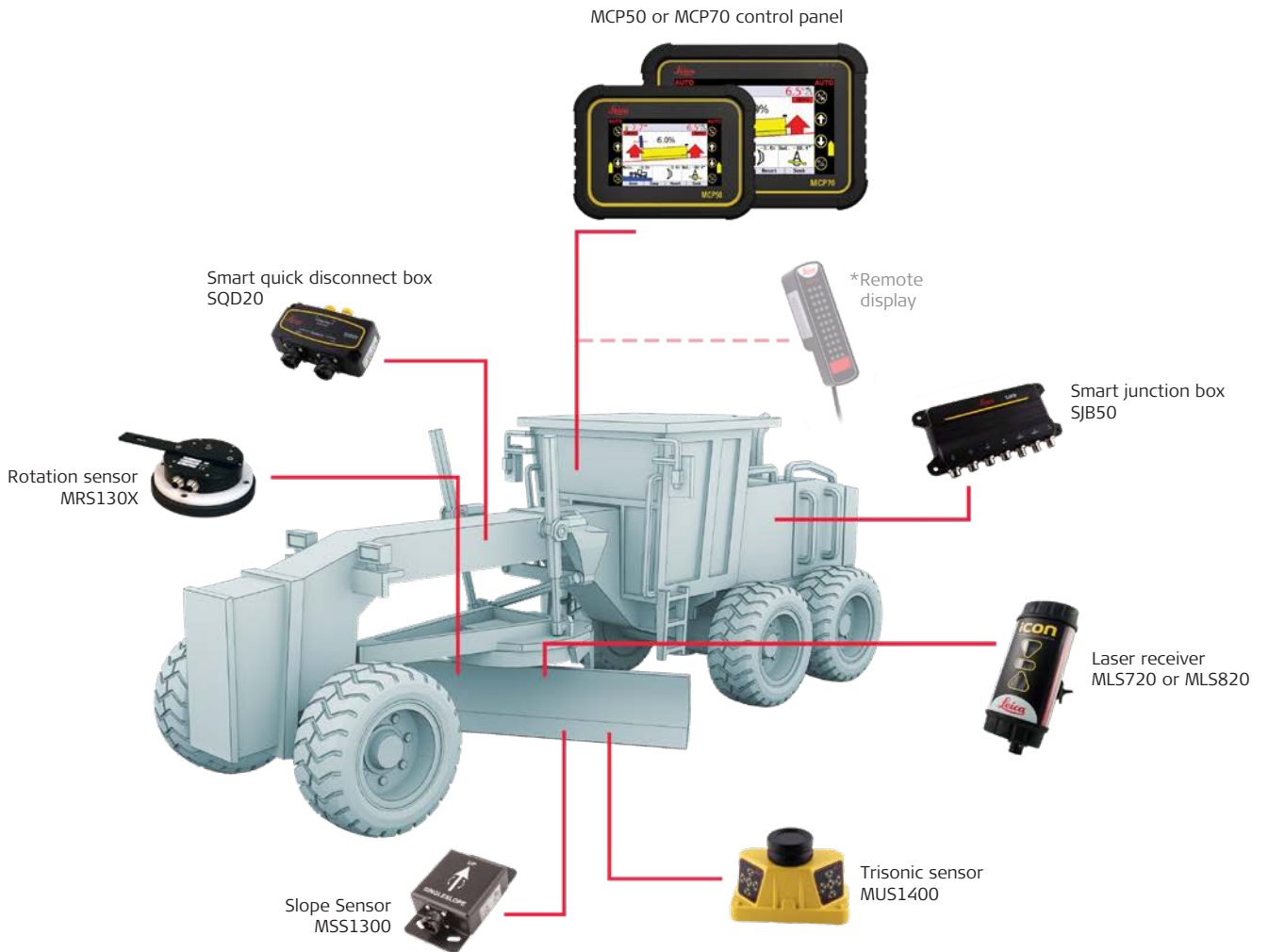

Other available options:



Dual laser receiver configuration

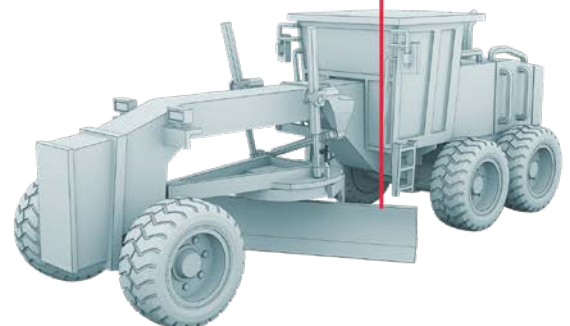

## Leica iCON iGG2

The Leica iCON 2D grade solution for motor graders offers innovative site preparation possibilities to advance your fleet. The system regulates the elevation and cross slope using robust, high-tech sensors. Integrate iCON iGG2 into your fleet and increase your operational performance while significantly decreasing material costs in construction projects.



# Wheel loader solution

Keeping your earthmoving tasks efficient safeguards your bottom line. Integrate 3D machine control technology seamlessly to your wheel loader and improve the speed of task completion. In addition, you ensure smooth grading to eliminate the need for rework and second attempts, which will reduce your project costs.



## Leica iCON iGW3

Our 3D machine control makes earthmoving with your wheel loader precise and easier. Adding guidance in the cab gives you absolute control over your work. Boost your skills and grade right the first time, improving the efficiency of earthmoving tasks.

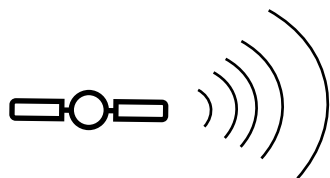

# Leica iCON iGW3 – Pioneering the future for wheel loaders

Advance on-site productivity by reducing rework and eliminating over-excavating and grade checking – exceptional benefits you will gain with our 3D machine control solution for wheel loaders. The Leica iCON grade iGW3 wheel loader system provides real-time bucket positioning, allowing the operator to apply instantaneous adjustments to the bucket position. The system uses 3D design models and state-of-the-art GNSS technology. The user-friendly interface presents design information and guidance on a dynamic colour display on the control panel in the cab. Offering modern navigation and real-time cut-and-fill indications, the iGW3 wheel loader solution will improve all production executions.



# Wheel loader 3D solution

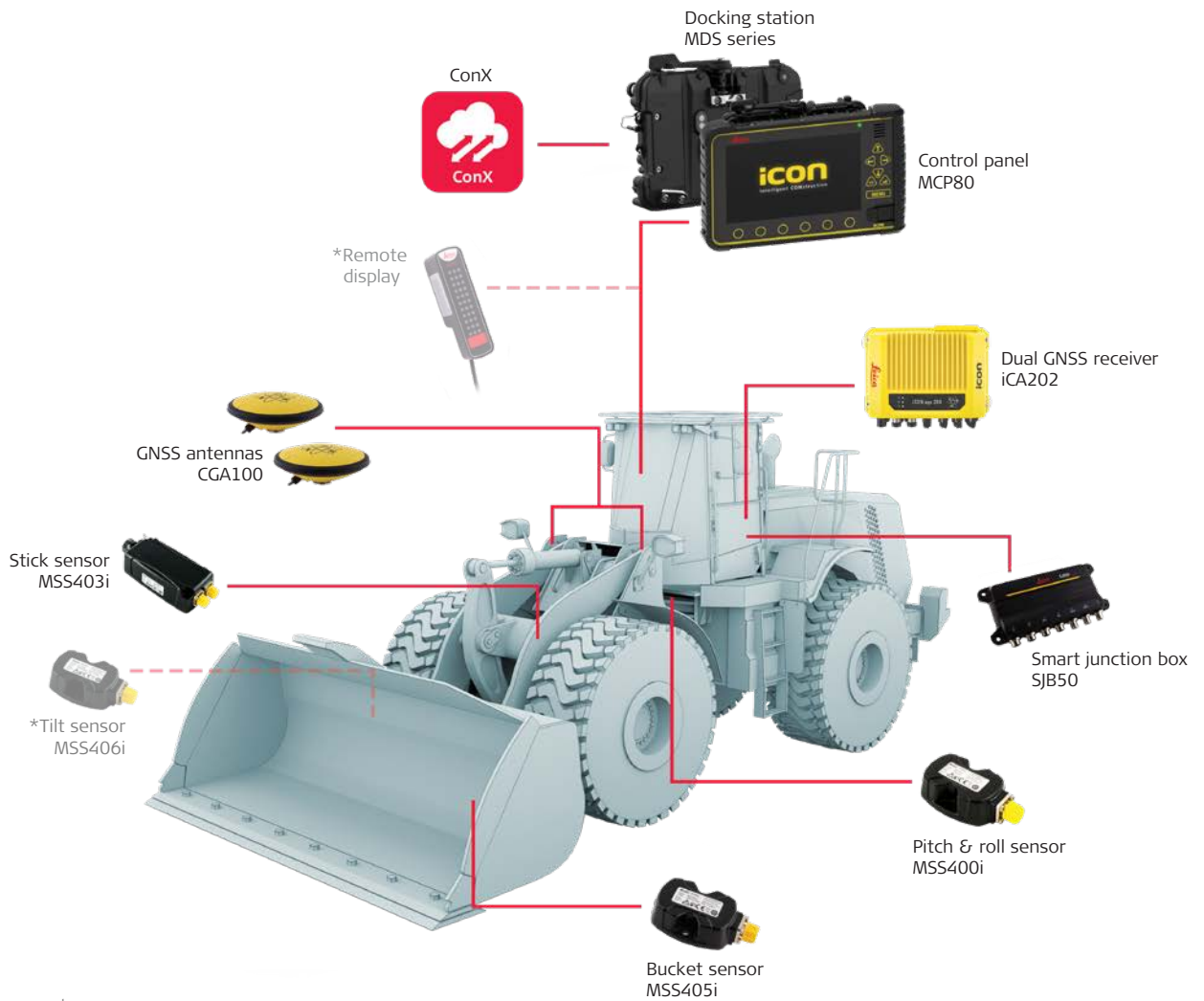

\* Optional components

## KEY BENEFITS

- Increase machine operating capabilities and return on investment from day one – get the grade right from the start
- Eliminate over-excavation and costly material overruns
- The intuitive user interface provides additional confidence and high productivity and reduces time and cost by minimum training needs
- Decrease re-work by utilising Leica MC1 software features to visualise real-time tool movements and live model updates
- Reduces labour costs by decreasing or eliminating grade checks

## Other available options:



Dual GNSS configuration with iCG120 & CR50

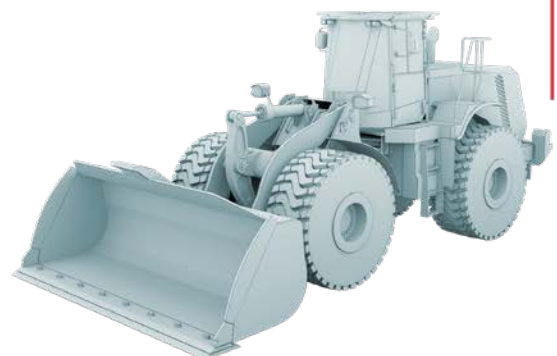





# Compact track loader & Skid-steer loader solution

Revolutionise your control on the construction site with powerful technology that gets your grading and levelling jobs done faster and right the first time, also when operating smaller construction machines. With our 3D machine control solution for compact track loaders and skid-steer loaders you will provide the operator with precision guidance, taking earthmoving to a higher level.



## Leica iCON iGW3

Make your time on the construction site more efficient. By integrating our innovative sensor technology and advanced 3D machine control software into your compact track loader and skid-steer loader, you can eliminate manual grade checking and avoid operator errors.

# Leica iCON iGW3 – Upgraded efficiency for compact track loaders & skid-steer loaders

Discover the advantages of machine control for your compact track loaders and skid-steer loaders with Leica iCON iGW3. Keep track of your bucket's position at all times and get real-time cut and fill indications in the cab on the control panel. Unleash new potential for your small loader machines, reinforce your earthmoving projects, and grade right the first time.



# Compact track loader & Skid-steer loader 3D solution



\* Optional components

## KEY BENEFITS

- Maximise your machine utilisation and return on investment from day one – get the grade right from the start
- Achieve the desired outcome with minimum passes
- Operator-friendly user interface reduces training time and cost
- Reduces labour costs by decreasing or eliminating grade checks
- Utilise Leica MC1 features, surface logging and Modify Models for real-time live updates and enhance your operating opportunities

## Other available options:



Dual GNSS configuration with iCG120 & CR50

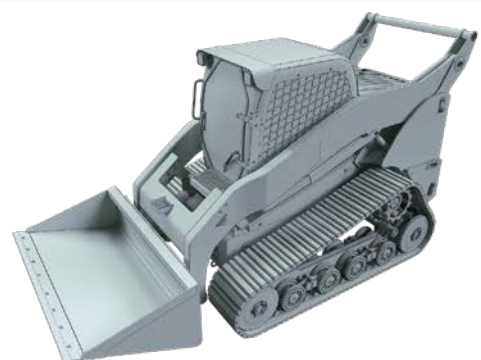



# Pile driver solution

Maximise safety and reduce project costs with our 3D piling solution. High-efficiency piling makes you more productive and enables you to use fewer people on site, optimising your resources. With automated applied documentation, there is no need to survey the finished project. Save time and costs with assisted navigation between piles and monitor your project progress through Leica ConX from the comfort of your office. All in all, our piling solution increases efficiency and shortens your project time.



## Leica iCON iRP3

The 3D piling solution offers a standard tower or body-mounted GNSS piler configuration in combination with an array of sensors for piling of pre-cast concrete piles, sheet wall and ground stabilisation.

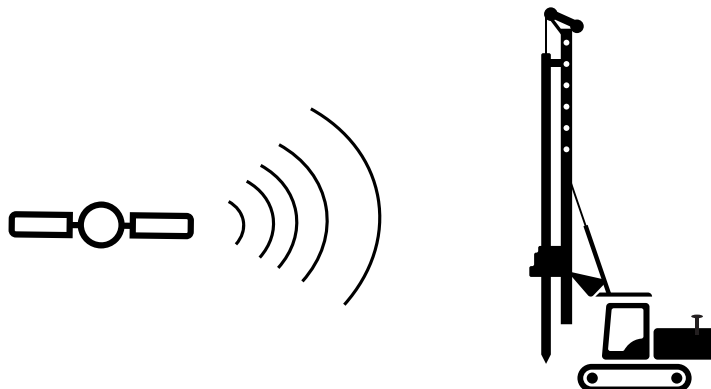

# Leica iCON iRP3 – Increase **efficiency** and **productivity** for pile drivers

The Leica iCON iRP3 solution for pilers fosters elevated productivity in piling applications. Piling rigs can be controlled easily from the cab on the control panel with a 3D design plan. There is no need to manually stake out the positions of the piles or sheets. Your piling jobs are further automated, decreasing **piling** errors and ensuring your projects are completed faster and more accurately.





#### KEY BENEFITS

- Get one solution for all your drilling and piling needs.
- Huge cost savings and increased safety due to less people on the site
- As applied documentation is automated, there is no need to survey the finished project
- Intuitive user friendly interface to enhance operator efficiency
- Fully customisable 3D views of machine and jobsite, modify your solution to your needs
- Save time and costs with faster navigation between piles
- Check on your projects progress from the comfort of your office
- Complete large piling projects in a short time

#### KEY FEATURES

- Document pile positions on-the-fly
- Navigate by auto-snap to nearest pile
- Get real-time status of your project with Leica ConX
- Quick and easy setup in Leica MC1 software to fit all preferences
- Choose between body mounting or tower mounting of GNSS antennas
- Bull's eye view for better target visualisation
- Split screen on the MCP80 run screen to combine bull's eye and cylinder view for advanced navigation

## Leica iCON iRP3

Export the 3D piling plan, upload it to Leica ConX, transfer the file to the machine, and get to work. With ConX, you can connect the entire construction site in one platform.

The Leica iCON 3D piler solution gives you maximum control. Guide your piler via the GNSS antennas and 3D design plans directly in the cab on the display. Automatically documenting the work as the project progresses means there is no need to survey the finished project.

## Leica ConX

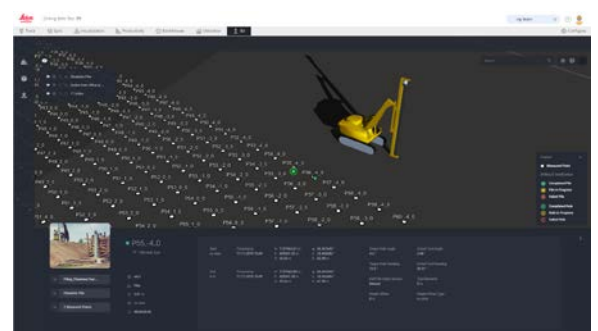

# Piler 3D solution

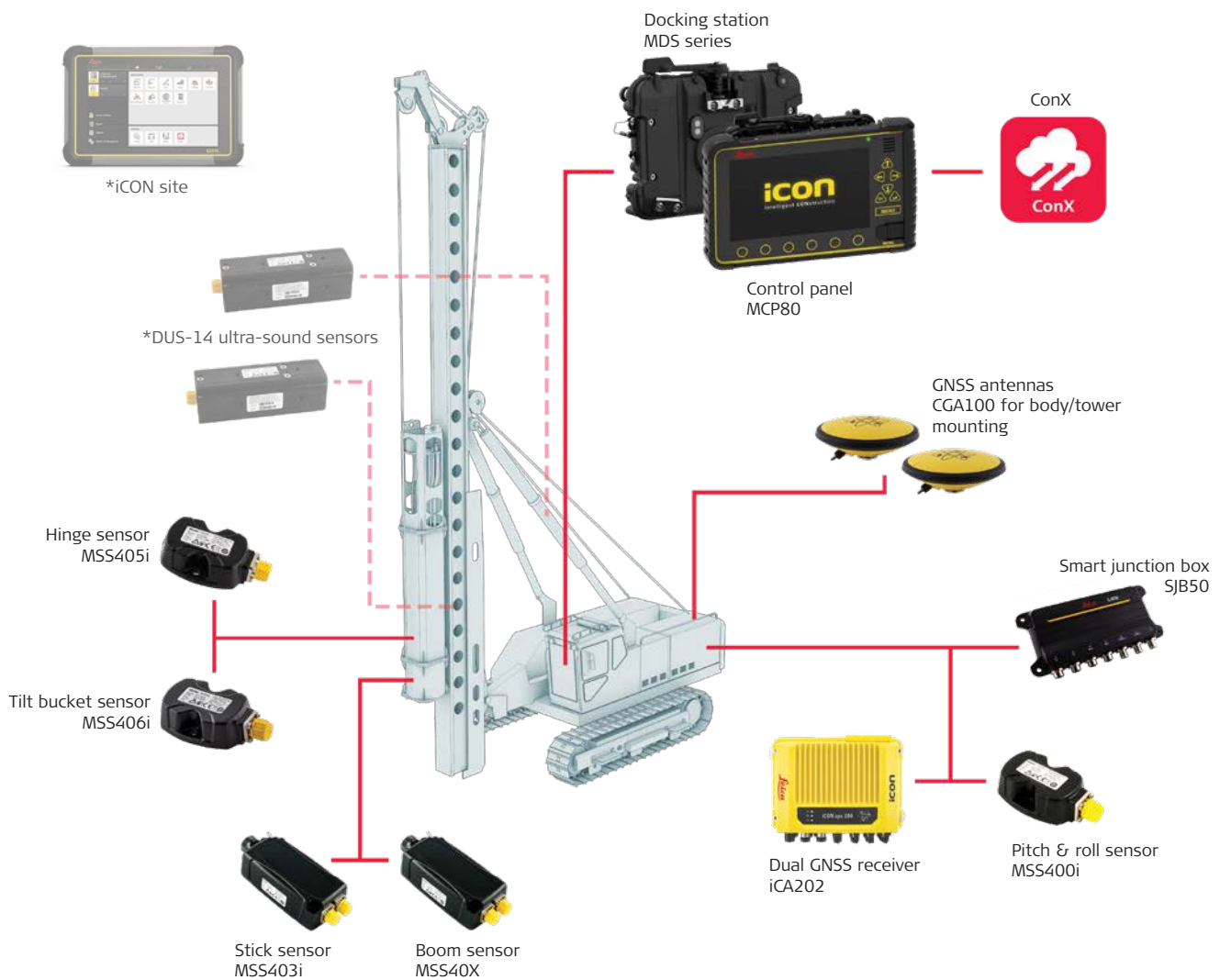

\* Optional components

## A user interface for all

The Leica iCON iRP3 piler solution's interface is simple and intuitive, with icons and help texts. The iRP3 assists the piler operator during the workflow, and the control panel run screen can be set up to suit the project task at hand.

The user interface displays the most relevant functions for pilers in the menu for easy access. The run screen view can be customised to suit your personal preferences, resulting in optimised operational efficiency.

### Other available options:



Dual GNSS configuration with iCG120 & CR50



Dual TPS and prism configuration



Depth measurement systems configuration

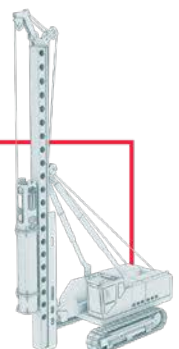



# Exact position, precise results



## Select run screen



### Bull's eye view

Leica MC1's navigation area is pulled into one single focus area to assist the machine operator and help focus on the task at hand with a full screen with bull's eye view.



### 3D view

The operator can choose to show the piler pattern in a colour-coded cylinder view. Green shows that a pile is driven successfully, red shows a failed pile, yellow shows a paused pile, and white cylinders show the piles to be piled. The auto-navigation functionality automatically navigates the operator to the nearest pile.



### Split screen view

The split screen run screen combines the advantages of both the bull's eye view and the cylinder view. It assist the operator in the piling work and lets the operator keep an eye on the navigation.



# Drill rig solution

Improve your drilling machine's productivity by adding Leica Geosystems machine control. Bring the 3D design plan inside the cab to eliminate the dependency on stakeouts, and work with advanced GNSS antennas and an array of sensors to help with precise and quick job completion. Directly supply the operator with a drill pattern to the machine control panel and navigate via GNSS to your next drilling location. Our innovative drilling solution allows for drilling complex patterns and even directional drilling.



## Leica iCON iRD3

Discover innovative drilling opportunities and potential with Leica iCON iRD3. Our solution offers you a standard tower or body mounted GNSS driller in combination with multiple sensors for surface drill rigs.

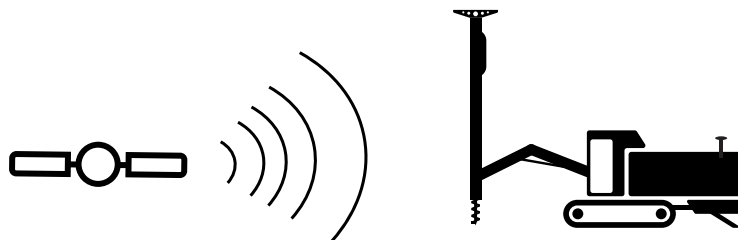

# Leica iCON iRD3 – Increase performance, accuracy and safety for drill rigs

The Leica iCON iRD3 driller solution empowers you with full control. The imported or created drill pattern guides the operator to the closest hole. When the position is within the horizontal tolerances, the operator now only needs to adjust and align the tower so that it fits the chosen hole angle and heading. The navigation is simple: Follow the arrows and numbers on the run screen, and align so that the bull's eye turns green, and you are ready to drill.



#### KEY BENEFITS

- One solution for all your drilling and piling needs on one iCON platform
- Easily operated and intuitive user interface to optimise productivity
- Customise the 3D views of your machine and jobsite to your personal preferences
- Huge time and costs savings with every drilling job
- Eliminate or drastically reduce stake out work
- Wireless update of project files and remote support via Leica ConX for the entire construction site
- Integration with manufacturers' on-board computer system
- Avoid drilling in old and failed holes

#### KEY FEATURES

- Drilling complex patterns is a breeze, even directional drilling is possible
- Create drill patterns directly on the display
- Log holes on-the-fly and share with entire site via Leica ConX
- Choose between body mounting or tower mounting of GNSS antennae
- Import drill patterns from Leica iCON site or Leica ConX
- Utilise dual bull's eye view to optimise target visualisation on the run screen
- Combine both bull's eye and cylinder view for optimal navigation support

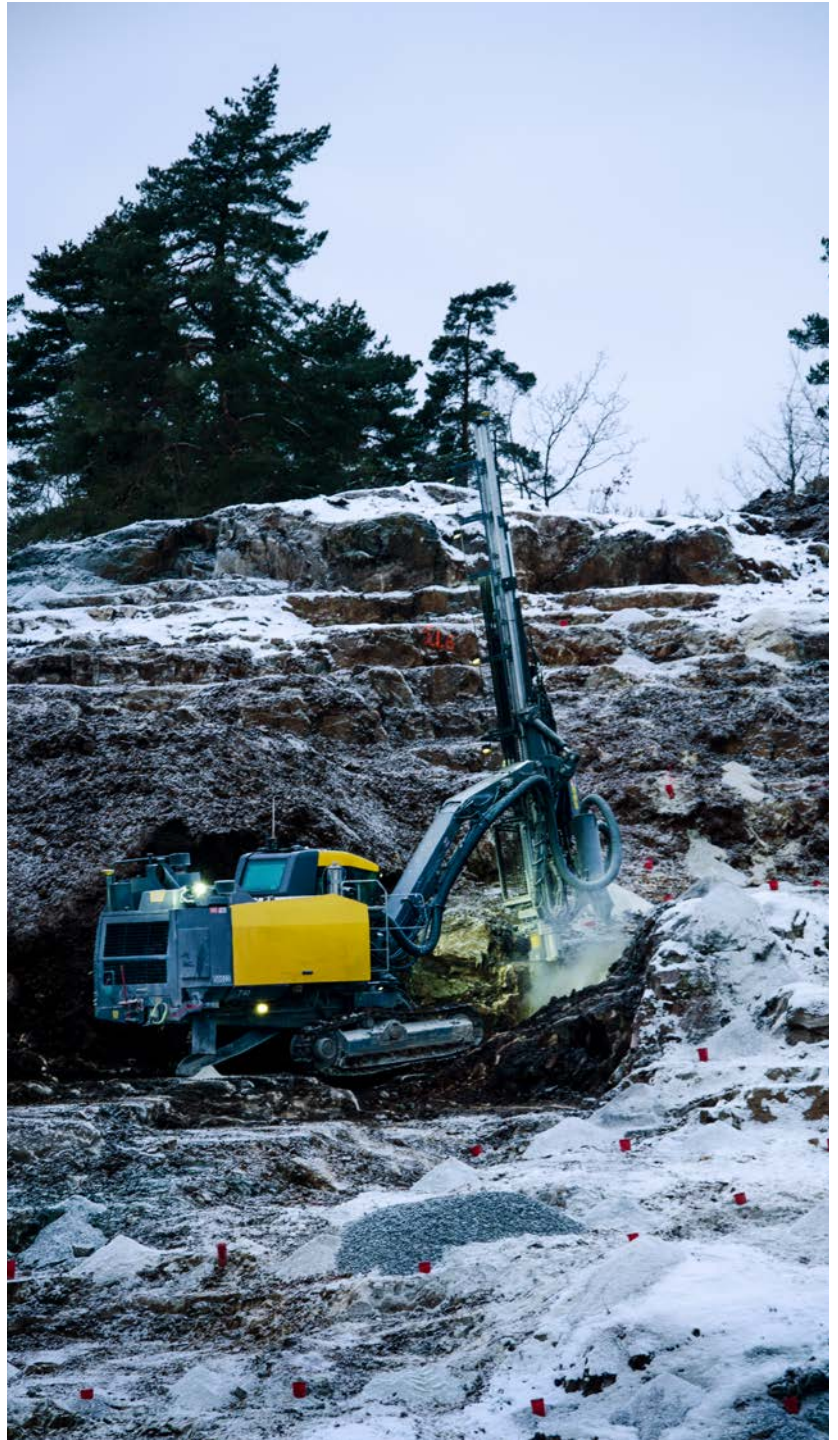

## Leica ConX

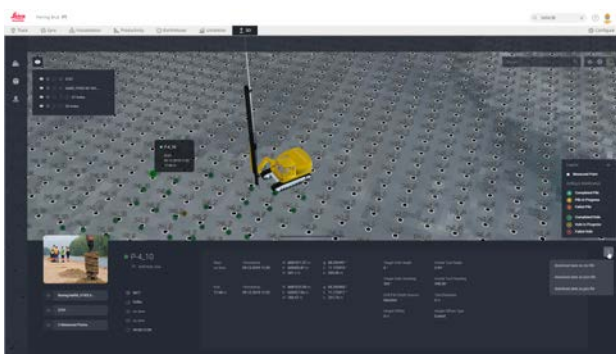

## Leica iCON iRD3

The control is in your hands with Leica iCON iRD3. Utilise our user-friendly MCP80 machine control panel and guide your driller using the GNSS antennas and 3D design plans directly from the comfort of the cabin. The panel allows for easy navigation and automatically documents the work as the project progresses, helping you avoid drilling in old and failed holes. By connecting the entire job site in one platform, Leica ConX, you can significantly improve the efficiency of your drilling projects.

Leica iCON iRD3 features multiple effective drilling applications to optimise your work. Drilling patterns and 3D models can be controlled on the MCP80 display, so there is no need to stake out the positions of the holes to be drilled.

# Driller 3D solution

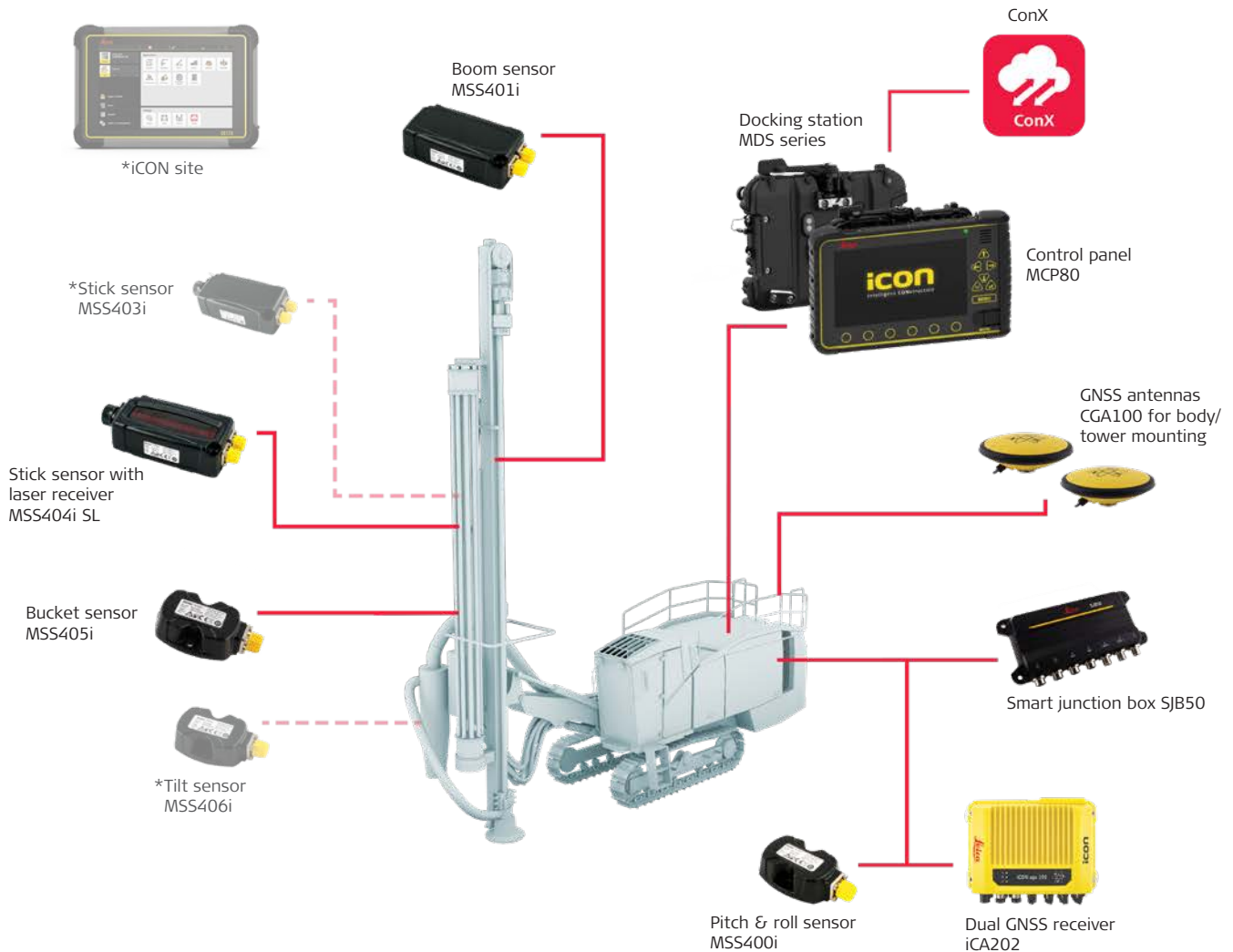

\* Optional components

## Other available options:



Dual GNSS configuration with iCG120 & CR50



Dual prism and TPS configuration

## Simple user interface

The user interface in iRD3 is simple and intuitive with icons and help texts. The iRD3 assists the driller operator throughout the entire workflow and the run screen can be set up to suit the task at hand. Use automatic navigation to nearest hole, bull's eye or cylinder view for easy navigation and auto-zoom for increased focus on the task. The interface displays the most relevant functions for drillers in the menu for easy access.



# Always in control



## Select run screen



### Dual Bull's eye view

With the Dual Bull's eye view, the operator can position the drill to hit the bottom target with a planned or an alternative angle. Daylight and night light modes are available.



### 3D view

The operator can choose to show the drill pattern in a colour-coded cylinder view. Green shows that a hole is drilled successfully, red shows failed hole and white cylinders show the holes to be drilled.



### Split screen view

The split screen run screen combines the advantages of both the bull's eye view and the cylinder view. It assist the operator in the drilling work as well as let's the operator keep an eye on the navigation.





# Compaction solution

Advance your compaction with the Leica iCON machine control. By utilising the Leica the iCON iCS3 solution for your soil compactor you can get your compaction jobs done faster, more efficient and right the first time. Save time and costs when you are able to avoid over and under compaction. Achieve smooth compaction results every time for a long-lasting foundation.



## Leica iCON iCS3

With the Leica iCON iCS3 solution, simplicity is key. It helps to monitor and document the compaction process while improving the compaction quality and reducing operational costs. Discover advanced technology that will make your compaction tasks more simple.

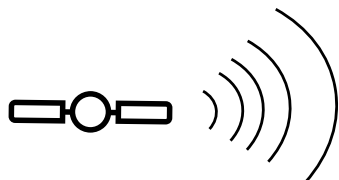

# Leica iCON iCS3 – Achieve **higher quality** in soil compaction

Give your soil roller the power of the Leica iCON machine control solutions. Leverage in the beneficial applications that will put you in full control and execute your tasks to perfection. Avoid over- or under compaction to save time and costs. Achieve smooth compaction results every time for a long-lasting foundation. iCON compaction makes roller operators' work easier. They can follow the information displayed on the MCP80 machine control panel to reach the desired target.

Unlock further opportunities for your iCON iCS3 solution with Leica ConX. The cloud solutions colour-coded map visualises the pass counts, CMV target, and CMV delta information in VETA and customisable styles. Combined with the quick and intuitive workflows, it allows the operator to adapt and carry out their tasks with ease. Data can wireless be transferred via ConX to enable office staff to monitor progress remotely and create as-built reports in a variety of options, including exporting the data to Leica or third-party software applications.



# Compaction 3D solution



## KEY BENEFITS

- Easy retrofittable for any roller brand and specification
- Versatility by supporting both single and dual GNSS configuration and total station position sensors
- Avoid over and under compaction and save fuel, time and rework
- Improved job site planning

## KEY FEATURES

- Stiffness indication application with integrated Compaction Meter Value (CMV) sensor
- Three use cases available: Pass count, CMV target, delta CMV
- Wireless data transfer between site and office for real-time monitoring of work progress
- Export of compaction data in Leica ConX for post process analysis
- Job reports for quality control or payment release via ConX

## Other available options:



Single & Dual GNSS configuration with iCG120 & CR50



TPS configuration with CR30s Robust LR BT Radio

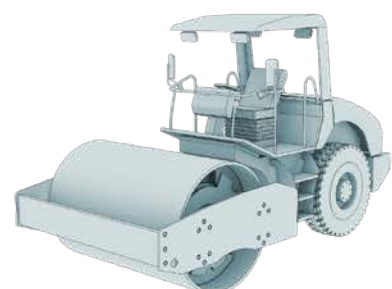



# Asphalt paving solution

Save time and costs by avoiding the dependency of string lines. Leica Geosystems offers 3D machine control solutions for any heavy construction application on your construction site. Leica iCON pave makes the paving work for asphalt operators and contractors easier and at lower costs. Stringless asphalt paving increases consistency and quality of the final paved surface.



## Leica iCON pave asphalt

Third generation 3D paving solution from Leica Geosystems - the 3D paving pioneer. The Leica iCON pave and Leica MC1 machine control software guides the paving machine with millimetre accuracy, ensuring superior results.

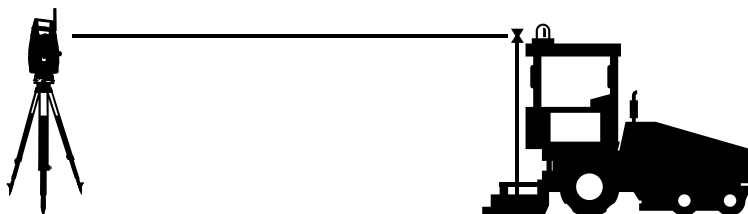

# Leica iCON pave for asphalt – 3D machine control for asphalt paving applications

Instantly upgrade your paving productions with our stringless guidance technology for your asphalt paver for successful executions every time. Increase accuracy, quality, and safety by removing the dependency on stringlines. With Leica iCON pave solutions, you can ensure exceptional end results and reduce road maintenance costs. Achieve an accurate paved surface and continuous paving using the Auto Leapfrog feature with the possibility of connecting up to 6 total stations to your paving production. The iCON pave solutions offer supreme sensor flexibility in Leica MC1 machine control software, which ultimately makes the paving job for asphalt operators and contractors easier and at lower costs.



## KEY FEATURES

- Automatic swap to an active spare total station when line of sight from total station to machine's prism is blocked with the Auto Leapfrog functionality
- Connect up to 6 total stations simultaneously with the all-in-one machine control software, Leica MC1
- Measured as-built information is sent to the MCP80 panel and synchronised with Leica ConX
- Monitor in real time and report with the Production Logging feature via ConX
- High end version includes width and steering control



# Leica iCON pave for asphalt – Assistive user interface

The Leica iCON pave for asphalt solution is designed to assist the operator through his work tasks. The machine control software, Leica MC1, provides an innovative user interface that makes you a proficient operator of paving productions. The interface's quick access allows the operator to have the most important functions at his fingertips, modified to his individual wants and needs, e.g., simple offset change for elevation and steering, tuning, and selection of total stations.



## PREPARATION

- Upload project data to the machine via Leica ConX
- Select reference line in the project
- Customise Leica MC1's runscreen to match the task at hand

## WORK PROGRESS

- Monitor work progress on the panel, and adjust the settings if required
- Perform as-built checks with a spare total station
- Reposition total station for Auto Leapfrog
- Analyse as-built files for work visualisation in Leica ConX

## QUALITY CONTROL

- Monitor project progress in real time and generate reports via Leica ConX
- Generate as-built documentation
- Use ConX for remote support

# Leica iCON pave for asphalt – Always in full control

## Dual GNSS & 1UP Configuration

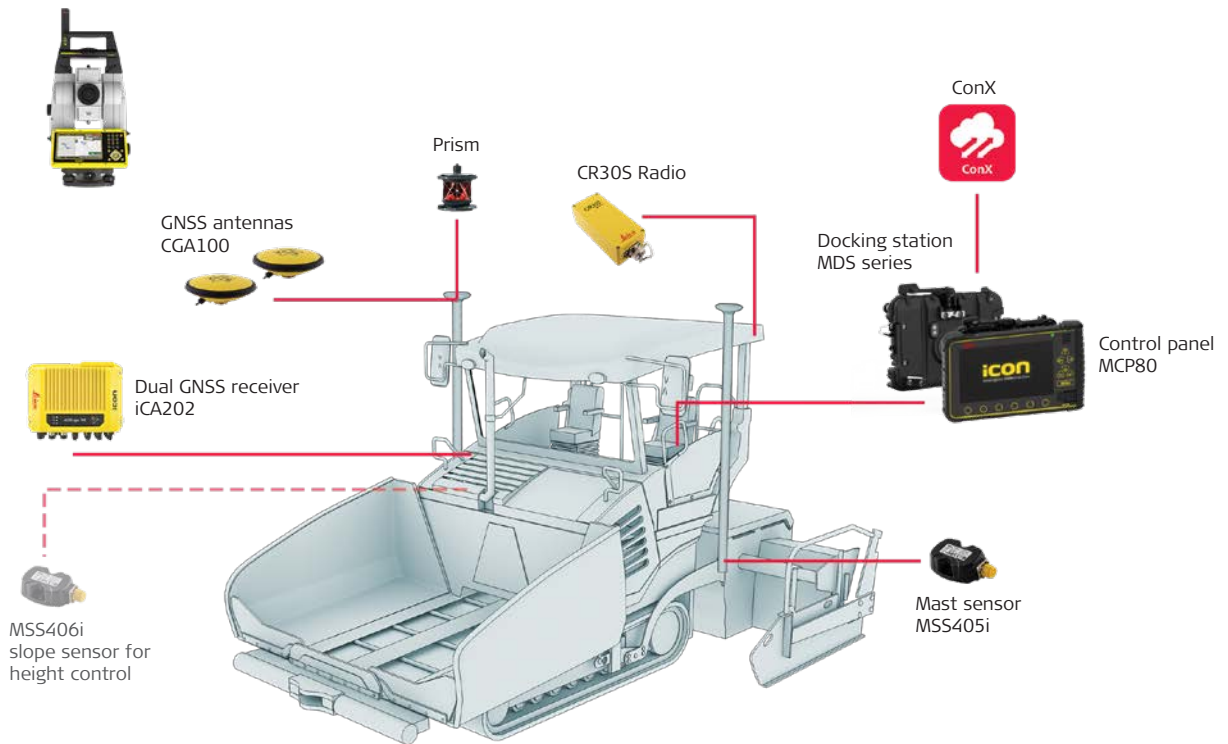

## TPS Configuration

\* Optional components

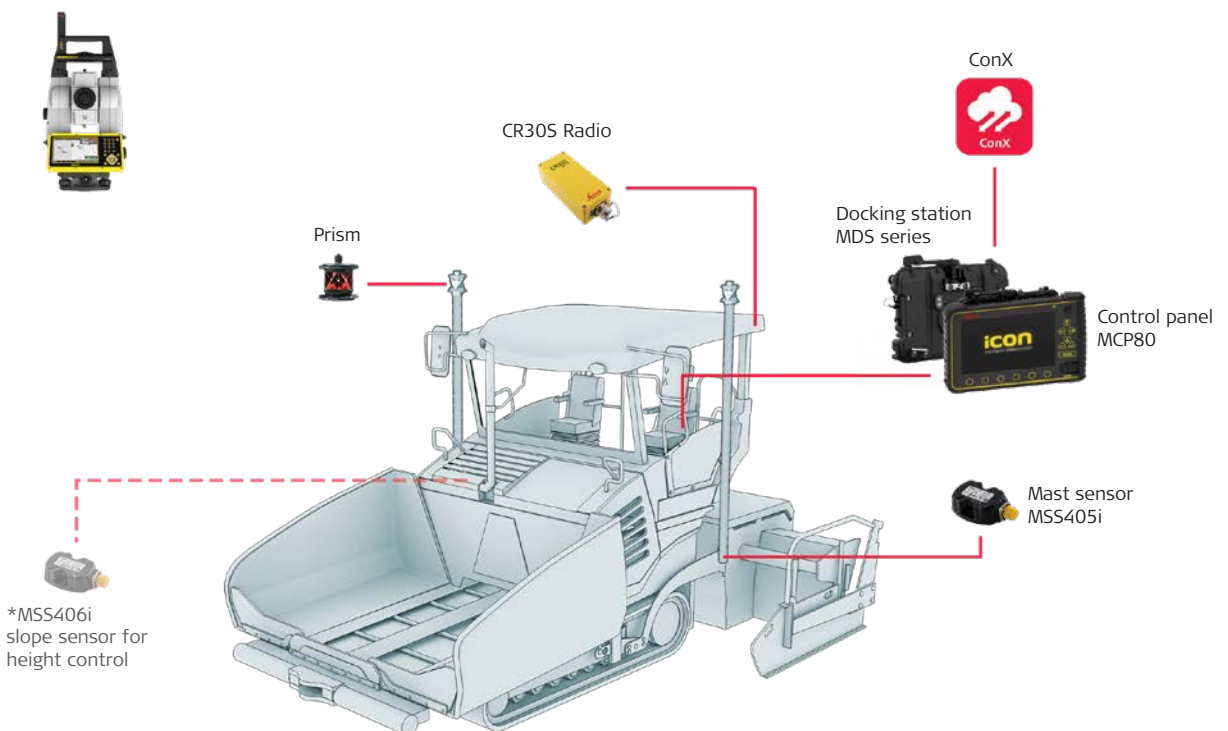



# Paving Production Logging – Production monitoring and reporting made easy

Paving Production Logging is a simple, easy-to-use analytics logging tool available for Paving & Cold milling production. This logging tool for the Leica iCON asphalt paving solution is developed with our customers in mind to increase their uptime by making paving production monitoring easy.

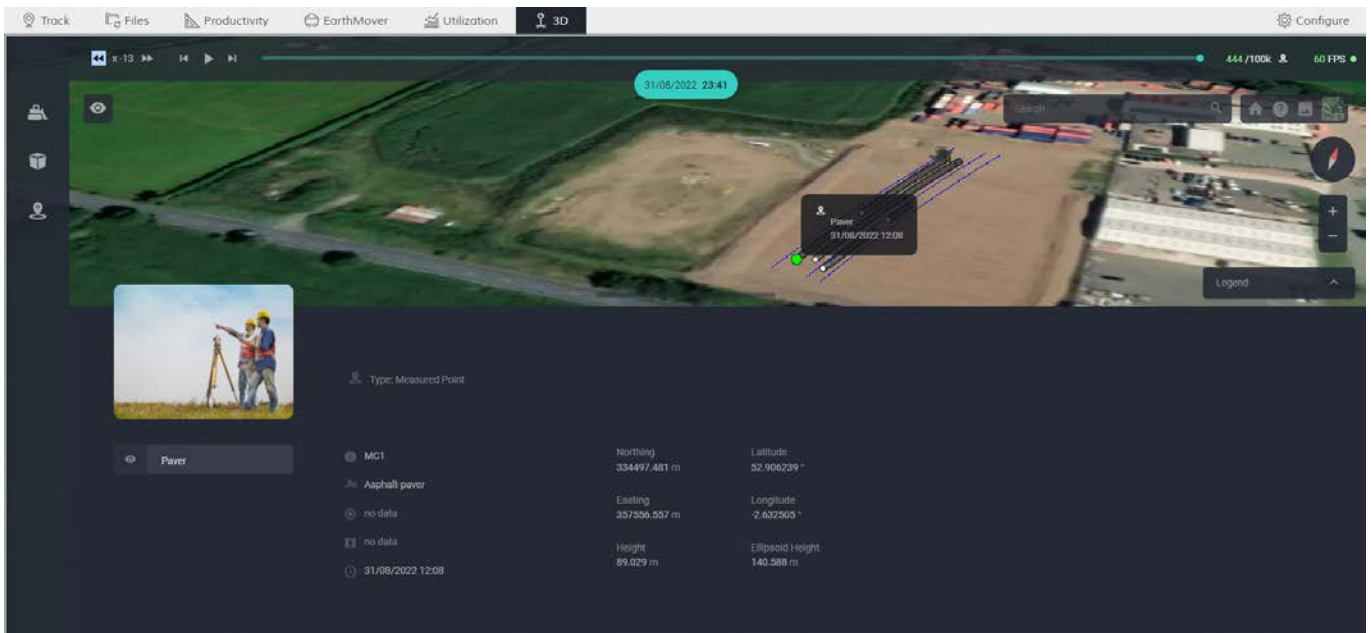

## KEY FEATURES

- Easy and customisable setup of auto-log parameters such as date/time, screed X, Y, Z model, speed, position sensors, offsets, run/stop mode, etc.
- Export logged files from Leica MC1 to USB to use in third party tools or use the auto-synch functionality when connected to Leica ConX
- Monitor production in near real-time from the office with Leica ConX
- Production Logging users can find the data in the 3D area in ConX
- Export the data to analyse your 3D production performance





# Milling solution

Unlock exceptional results on the construction site with Leica iCON machine control solutions for your milling machines. Implement cutting-edge technology and execute your milling operations error-free, at greater speed, and with enhanced efficacy. Benefit from project cost reductions and time savings when you can minimise the manual work of spraying and typing in values.



## Leica iCON pave for milling

Our 3D milling solution ensures a smooth and even milled surface preparing the ground for later asphalt paving, saving time and costly asphalt mix. iCON pave makes the milling work for the operator and contractor easier and at lower costs.

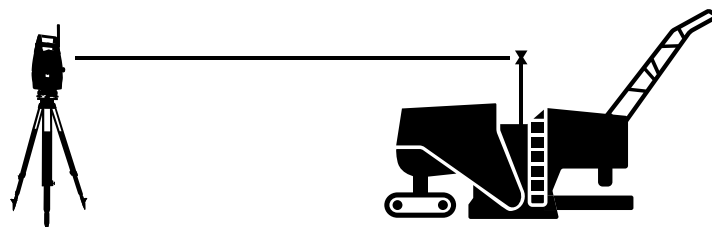

# Leica iCON pave for milling – 3D machine control for cold planers

The Leica iCON pave milling solution is designed to advance and assist the operator through his work tasks. The machine control solution and software allow for a personalised user interface, letting the operator modify the interface to include the most important functions that fit the needs of a current task. Optimising on-site productivity with speedy access to needed applications, such as changing offset for elevation and setting up total stations or GNSS. Measured as-built information is sent to the MCP80 panel and then synchronised with Leica ConX.



# 3D milling solution

## Dual GNSS & 1UP

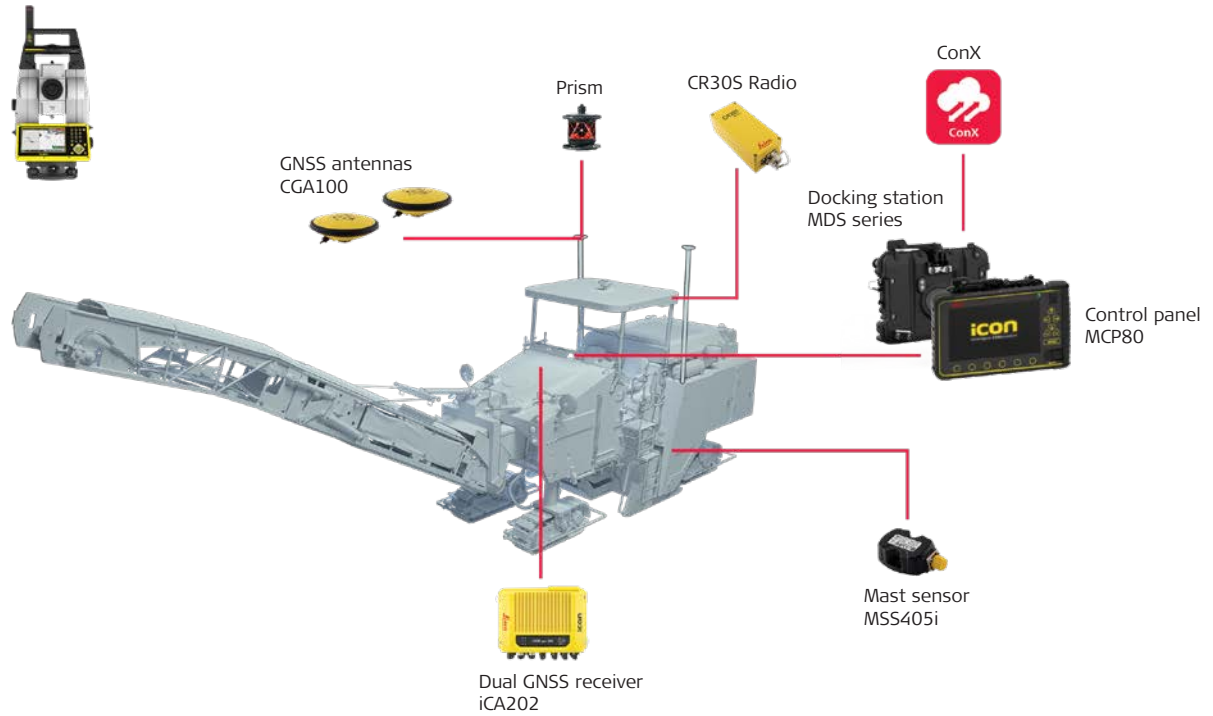

\* Optional components

## TPS Configuration

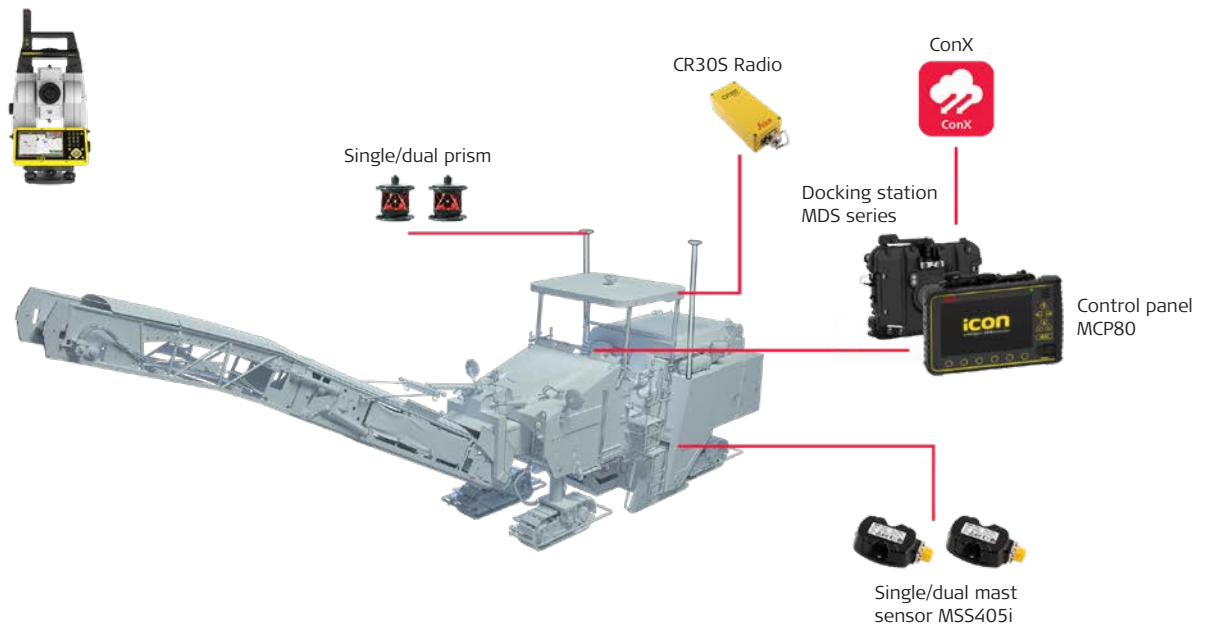

# Leica iCON pave for milling – Powerful technology for cold planers



## KEY FEATURES

- Auto Leapfrog for continuous work process
- Many sensor combinations possible to suit every milling need
- Track, view and sync via Leica ConX
- Optional patented 1UP sensor configuration for complex projects like race tracks with slope in curves

## KEY BENEFITS

- Easy retrofittable for any cold planer brand and specification
- Correct grade and slope without copying effect saving fuel, time and avoiding rework
- Accurate milling surface according to the design model avoids subsequent over paving with costly asphalt mix
- Seamless workflow between milling and asphalt paving to shorten project time
- Improved planning and safety on site

## PREPARATION

- Upload project data via Leica ConX
- Select reference line in project
- Customise the screen for the required use case
- Position cold planer for milling start

## WORK PROGRESS

- Start moving the cold planer and mill automatically to the required level
- Monitor work progress on the panel
- As-built checks with spare total station

## QUALITY CONTROL

- Monitor project progress in real time in Leica ConX
- Use ConX for remote support

# Leica iCON site milling pilot – Differential GNSS milling machine solution

Leica iCON site milling pilot is your first step into digitised GNSS milling. Control the precise cutting depth and gain from increased productivity, higher precision and smoother surfaces by moving away from traditional methods in the re-paving process. Forget about losses in milling quality resulting from vague or missing spray marks. The iCON site milling pilot calculates the difference between the existing and the design surface at the cold planers' current position. In addition, set values at predicted points ahead of the current position are calculated.







# Concrete paving solution

From highways to airfield to tunnel construction and beyond, the comprehensive Leica Geosystems solution set can be easily configured to your needs with the leading OEM paver manufacturers. Our intelligent paving automation, industry-leading positioning sensor solutions, and intuitive Leica MC1 user interface deliver unmatched 3D performance. Giving you the edge over your competition with your paving production.



## Leica iCON pave for concrete paving

Take control and become empowered on the construction site with Leica iCON pave, the ultimate in 3D paving solutions for slip-form pavers, curb and gutter, placer spreaders, and trimmer machines.

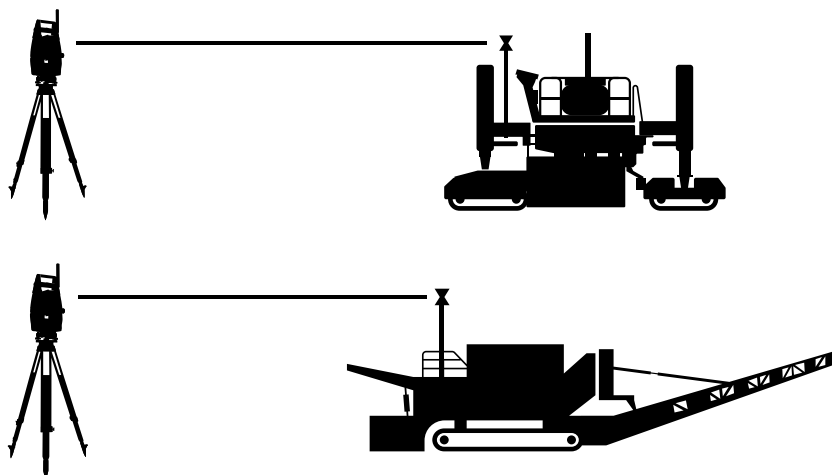

# Leica iCON pave concrete – 3D paving solutions for concrete pavers

Leica iCON pave supports your business with 3D paving solutions for airport paving, tunnel work, curb and gutter jobs, and new highway projects. With decades of experience in 3D paving solutions, Leica Geosystems, part of Hexagon, has proven expertise in hundreds of installed and active systems worldwide and numerous approved interfaces with all main OEMs. Complete your paving jobs faster, with elevated efficiency, and right the first time with the concrete paving solution from Leica iCON machine control solutions.



# Concrete paving solution

## Concrete paver

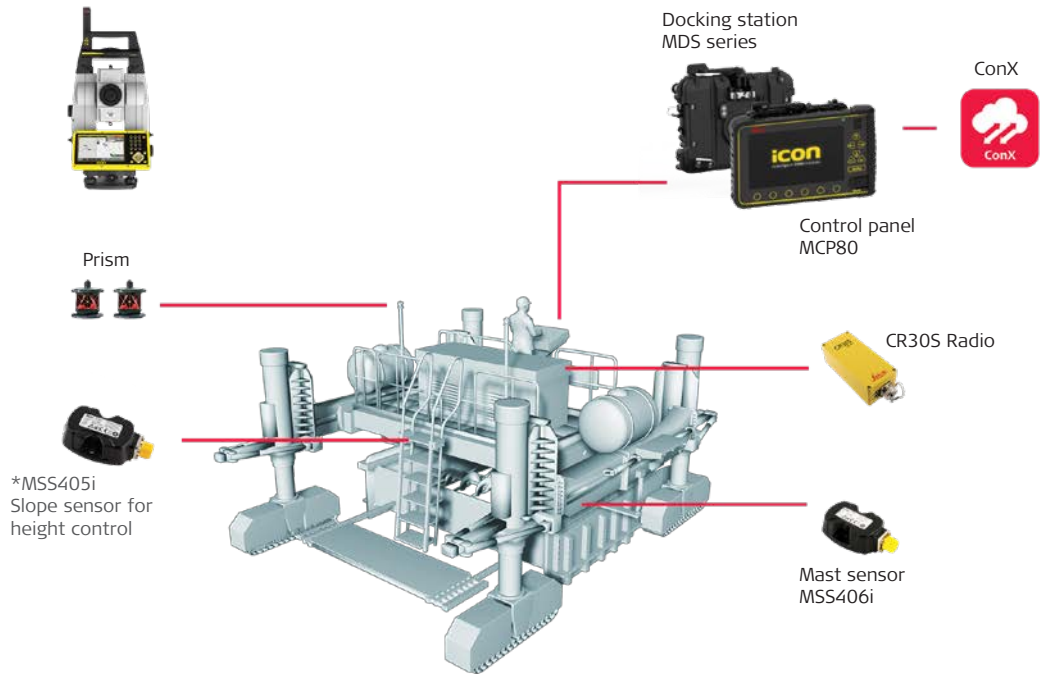

## Placer & Spreader

\* Optional components

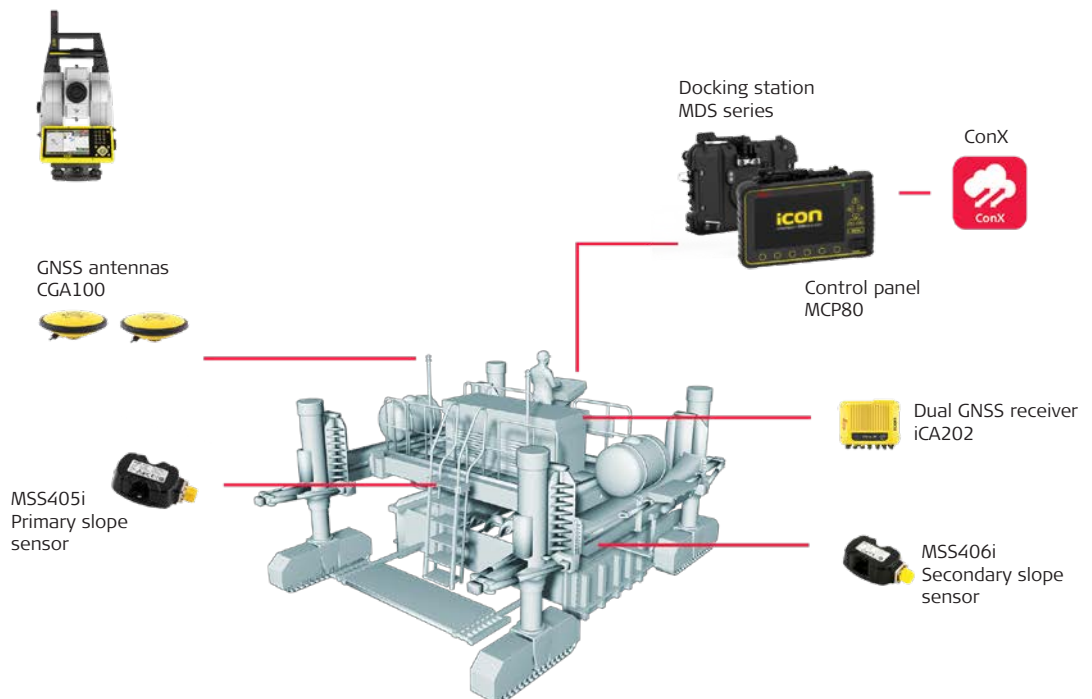

## Enhancing update and work efficiency

The Leica iCON pave solution offers a machine calibration wizard for easy set-up of the machine. Useful help functions can assist the operator in his work and remote support and communication is helpful tool for the operator to receive information from the site office or from a surveyor. The assistive software ensures better communication and consequently more uptime and productivity.

# Curb & Gutter solution

## Dual GNSS & 1 UP configuration

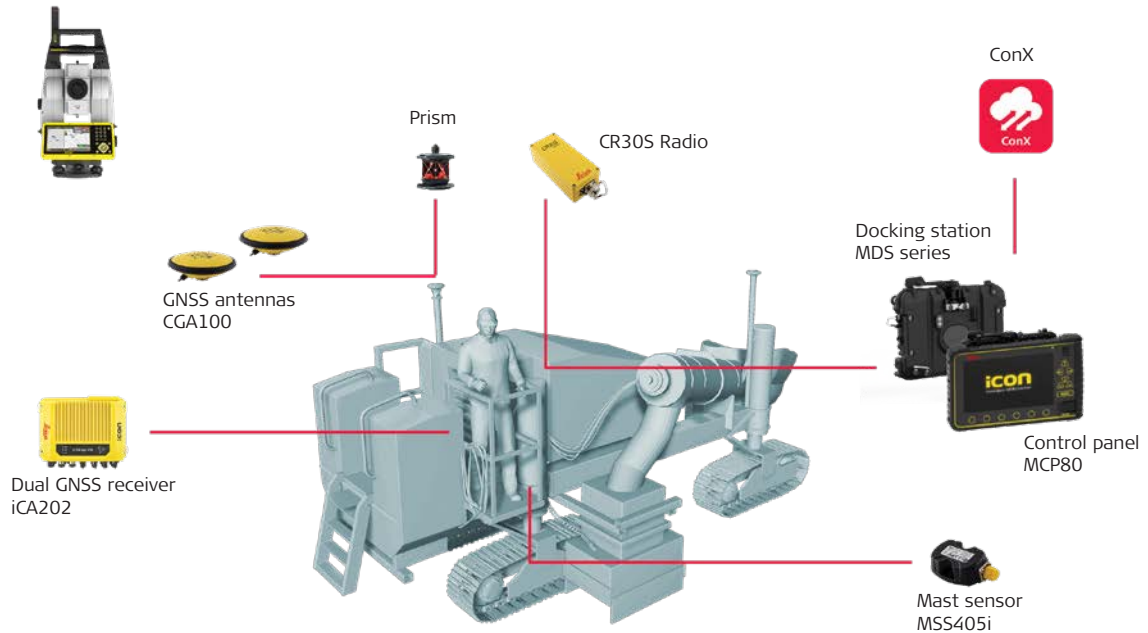

\* Optional components

## Dual TPS configuration

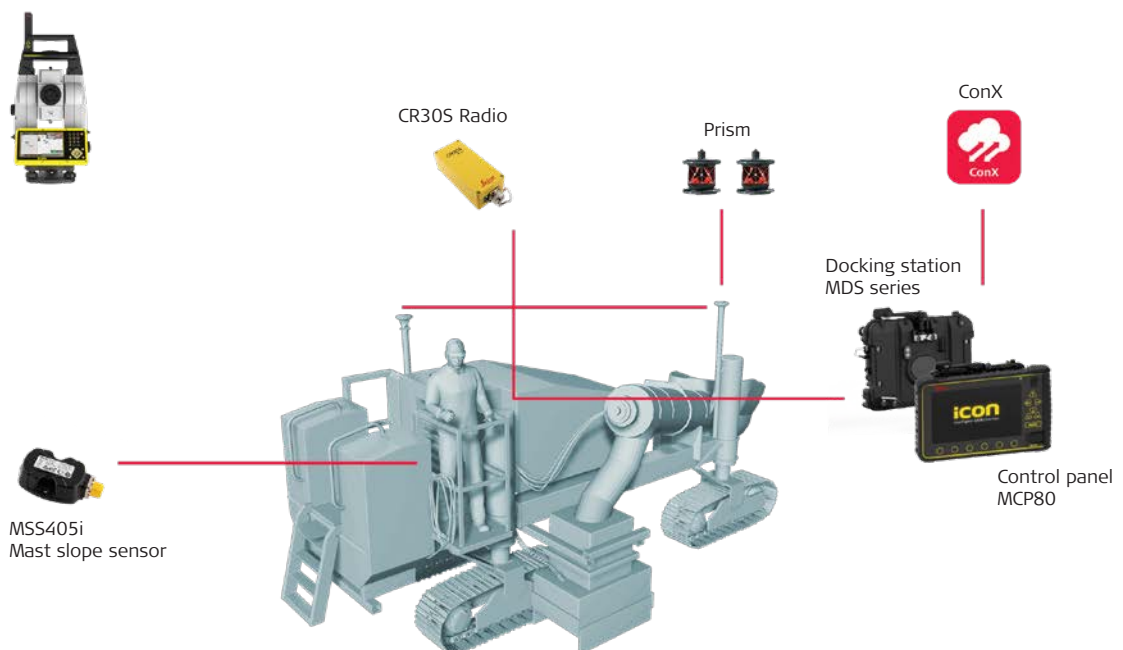



#### KEY FEATURES

- Intelligent hardware combination of panel and machine mounted cradle storing machine specific data
- Smooth workflows due to complete Leica iCON product portfolio for any construction site application
- 1UP sensor configuration combining total station and prism with dual GNSS system
- Automatically swap to the active spare total station when line of sight from total station to machine's prism is blocked with the Auto Leapfrog functionality
- Connect up to 6 total stations simultaneously in our all-in-one machine control software, Leica MC1
- Leica MC1 can auto-send a CAN message when the dowel bars should be inserted in the concrete based on the design file with the Fire by Leica feature

#### KEY BENEFITS

- Consistent and highly accurate pave quality as the third generation of iCON stringless paving solutions
- Ensure exceptional end-results through continuous paving operation using the Auto Leapfrog and Fire by Leica features
- Easy adaptation to any job site conditions with several sensor combinations
- Reduced cabling and costs with the multipoint radio
- Supported by Leica ConX for track, view and synchronisation

# Leica iCON pave concrete – Monitor progress in Leica ConX

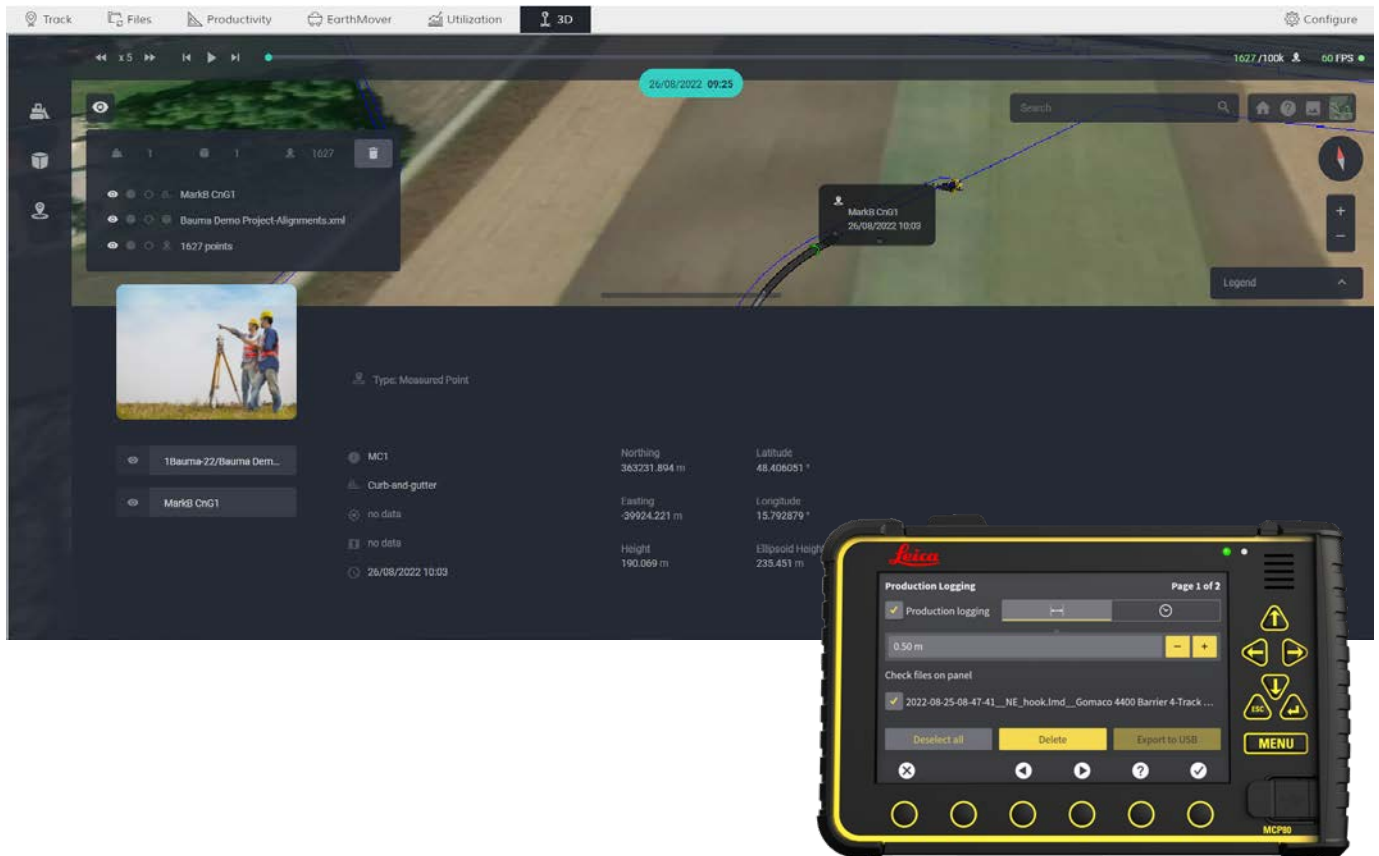

## PREPARATION

- Upload stringline road models via Leica ConX
- Select reference and slope line on the display
- Customise the run screen
- Activate multipoint radio
- Set up total station (Auto Leapfrog)

## WORK PROGRESS

- Monitor material flow while in auto run mode
- Use quick access keys to off-set/tune set safety features for job adaptations

## QUALITY CONTROL

- Log as-builts
- Monitor progress in Leica ConX

## PAVING PRODUCTION LOGGING

- Paving Production Logging is a simple, easy-to-use analytics logging tool available for paving & cold milling production
- Easy and customisable setup of auto-log parameters such as date/time, mould/head X, Y, Z model, speed, position sensors, offsets, run/stop mode, etc.
- Export logged files from MC1 to USB to use in third party tools or use the auto-synch functionality when connected to Leica ConX
- Monitor production in near real-time from the office with Leica ConX or export the data to analyse your 3D production performance
- With the Auto-synched functionality in Leica ConX, Production Logging users can find the data in 3D area
- Filter as-built files for easy tracking in Leica ConX



# Customer Care Packages – Maintenance contracts

Customer Care Packages (CCPs) bundle Product Care and Customer Care together to ensure you achieve maximum value from your investment in machine control solutions. When you buy a CCP from Leica Geosystems, you have peace of mind that nothing stands between you and your productivity. Our global network of professional support and service teams are next to you with local domain knowledge, product expertise and the latest technology tools to keep your operations running. You can simply count on us!

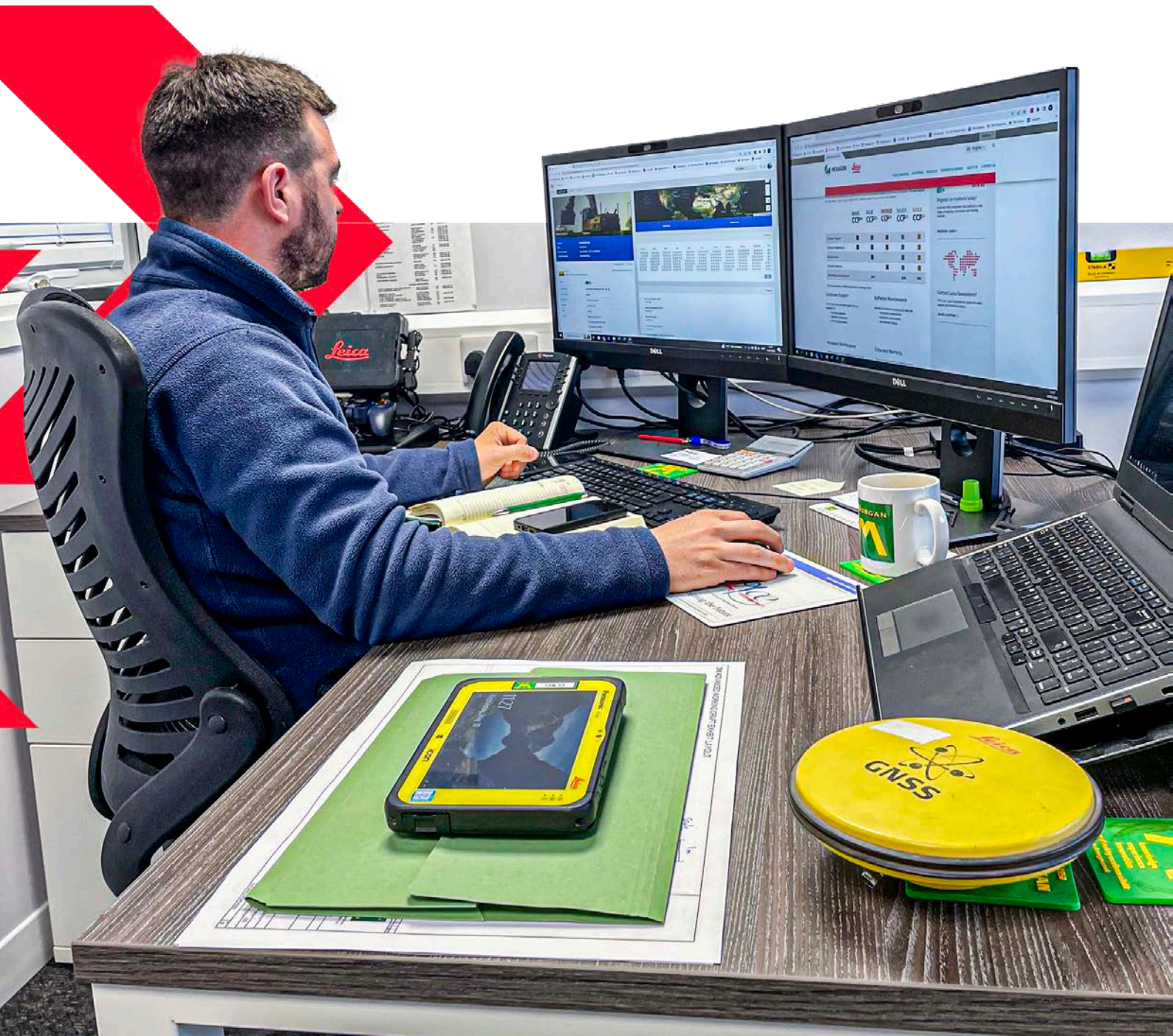





Global Components	BASIC CCP	BLUE CCP	BRONZE CCP	SILVER CCP
Customer Support	■	■	■	■
Software Maintenance	■	■	■	■
Field Service		■		■
Extended Warranty			■	■
Local Benefits	■	■	■	■
Online Training	■	■	■	■



### Customer Support

Direct hotline during office hours and web-based support for:

- Operational questions, issues, and general advice
- Remote support through Leica ConX\*
- Online and on-demand training



### Field Service

Professional local technician support to provide:

- Annual preventive machine inspection
- Yearly maintenance and calibration
- Certificate of system performance



### Software Maintenance

Maximise productivity by staying up to date with:

- Performance improvements
- Application enhancements
- New Software features



### Extended Warranty

Extend coverage beyond the standard warranty:

- Security for unforeseen failures
- Avoid unplanned costs
- Up to five years of coverage



### Local Benefits

Each sales office enhances the standard Customer Care Package with local resources, delivery networks, local language, and knowledge of local methods.

\*Available only for machines with Leica MC1 software V6.2 or later.





## Leica Geosystems – when it has to be right

With more than 200 years of history, Leica Geosystems, part of Hexagon, is the trusted supplier of premium sensors, software and services. Delivering value every day to professionals in surveying, construction, infrastructure, mining, mapping and other geospatial content-dependent industries, Leica Geosystems leads the industry with innovative solutions to empower our autonomous future.

Hexagon (Nasdaq Stockholm: HEXA B) has approximately 24,000 employees in 50 countries and net sales of approximately 5.2bn EUR. Learn more at [hexagon.com](https://hexagon.com) and follow us @HexagonAB.



Copyright Leica Geosystems AG, 9435 Heerbrugg, Switzerland. All rights reserved. Printed in Switzerland – 2024. Leica Geosystems AG is part of Hexagon AB. 888095en – 06.24



Leica iCON gps 120 brochure



Leica iCON gps 160 brochure



Leica iCON gps 70 series brochure

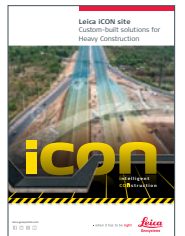

Leica iCON site brochure